

# **TECHNICAL & SERVICE MANUAL**

---

Models

**PEFY-WP10VMS1-E  
PEFY-WP15VMS1-E  
PEFY-WP20VMS1-E  
PEFY-WP25VMS1-E  
PEFY-WP32VMS1-E  
PEFY-WP40VMS1-E  
PEFY-WP50VMS1-E**

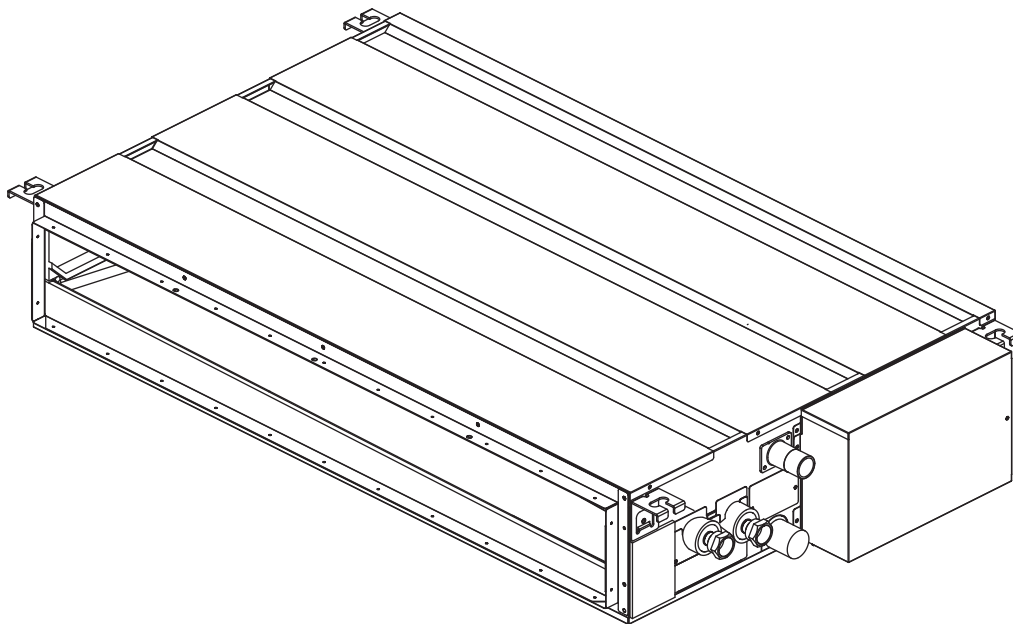

**2nd edition**

**CITY MULTI**

# Safety Precautions

## Read before installation and performing electrical work

- Thoroughly read the following safety precautions prior to installation.
- Observe these safety precautions for your safety.
- This equipment may have adverse effects on the equipment on the same power supply system.
- Contact the local power authority before connecting to the system.

### Symbol explanations



#### WARNING

This symbol indicates that failure to follow the instructions exactly as stated poses the risk of serious injury or death.



#### CAUTION

This symbol indicates that failure to follow the instructions exactly as stated poses the risk of serious injury or damage to the unit.



Indicates an action that must be avoided.



Indicates important instructions.



Indicates a parts that requires grounding.



Indicates that caution must be taken with rotating parts. (This symbol is on the main unit label.) <Color: Yellow>



Indicates that the parts that are marked with this symbol pose a risk of electric shock. (This symbol is on the main unit label.) <Color: Yellow>



#### WARNING

Carefully read the labels affixed to the main unit.



#### WARNING

- Do not use refrigerant other than the type indicated in the manuals provided with the unit and on the nameplate.
- Doing so may cause the unit or pipes to burst, or result in explosion or fire during use, during repair, or at the time of disposal of the unit. It may also be in violation of applicable laws. MITSUBISHI ELECTRIC CORPORATION cannot be held responsible for malfunctions or accidents resulting from the use of the wrong type of refrigerant.
- Ask your dealer or a qualified technician to install the unit.
- Improper installation by the user may result in water leakage, electric shock, or fire.
- Properly install the unit on a surface that can withstand its weight.
- Unit installed on an unstable surface may fall and cause injury.
- Only use specified cables. Securely connect each cable so that the terminals do not carry the weight of the cable.
- Improperly connected cables may produce heat and start a fire.
- Take appropriate safety measures against wind gusts and earthquakes to prevent the unit from toppling over.
- Improper installation may cause the unit to topple over and cause injury or damage to the unit.

- Only use accessories (i.e., air cleaners, humidifiers, electric heaters) recommended by Mitsubishi Electric.
- Do not make any modifications or alterations to the unit. Consult your dealer for repair.
- Improper repair may result in water leakage, electric shock, or fire.
- Do not touch the heat exchanger fins with bare hands.
- The fins are sharp and pose a risk of cuts.
- Properly install the unit according to the instructions in the Installation Manual.
- Improper installation may result in water leakage, electric shock, or fire.
- Have all electrical work performed by an authorized electrician according to the local regulations and the instructions in this manual. Use a dedicated circuit.
- Insufficient power supply capacity or improper installation of the unit may result in malfunctions of the unit, electric shock, or fire.

---

 **WARNING**

Keep electrical parts away from water.

Wet electrical parts pose a risk of electric shock, smoke, or fire.

Securely attach the control box cover.

If the cover is not installed properly, dust or water may infiltrate and pose a risk of electric shock, smoke, or fire.

Only use the type of refrigerant that is indicated on the unit when installing or relocating the unit.

Infiltration of any other types of refrigerant or air into the unit may adversely affect the refrigerant cycle and may cause the pipes to burst or explode.

Consult your dealer or a qualified technician when moving or reinstalling the unit.

Improper installation may result in water leakage, electric shock, or fire.

After completing the service work, check for a refrigerant leak.

If leaked refrigerant is exposed to a heat source, such as a fan heater, stove, or electric grill, toxic gases will be generated.

Do not try to defeat the safety features of the unit.

Forced operation of the pressure switch or the temperature switch by defeating the safety features for these devices, or the use of accessories other than the ones that are recommended by Mitsubishi Electric may result in smoke, fire, or explosion.

Consult your dealer for proper disposal method.

## Precautions for handling units for use with water

 **CAUTION**

Do not use the existing water piping.

Store the piping materials indoors, and keep both ends of the pipes sealed until immediately before installation. Keep the joints wrapped in plastic bags. If dust or dirt enters the water circuit, it may damage the heat exchanger and cause water leakage.

Only use water.

Only use clean water as a refrigerant. The use of water outside the specification may damage the refrigerant circuit.

# CONTENTS

---

## I Features

[1] Features.....	1
-------------------	---

## II Components and Functions

[1] Components and Functions.....	2
-----------------------------------	---

## III Specifications

[1] Specifications.....	3
1.Specifications .....	3
2.Electrical component specifications.....	5

## IV Outlines and Dimensions

[1] Outlines and Dimensions.....	6
----------------------------------	---

## V Wiring Diagram

[1] Wiring Diagram.....	8
-------------------------	---

## VI Refrigerant System Diagram

[1] Refrigerant system diagram.....	10
-------------------------------------	----

## VII Troubleshooting

[1] Troubleshooting .....	11
1.Check methods.....	11
2.DC fan motor (fan motor/indoor control board).....	13
3.Address switch setting .....	14
4.Voltage test points on the control board .....	15
5.Dipswitch setting (Factory setting).....	16
6.Instructions for debris removal operation.....	18
7.Instructions for the air vent operation .....	18

## VIII Disassembly Procedure

[1] Disassembly Procedure.....	19
1.Control box .....	19
2.Thermistor (Intake air) .....	20
3.Drainpan .....	21
4.Thermistor (Water outlet) (Water inlet) .....	22
5.Fan and fan motor .....	23
6.Bearing .....	24
7.Heat exchanger .....	25
8.Drain pump .....	26
9.Float Switch .....	27

**[1] Features**

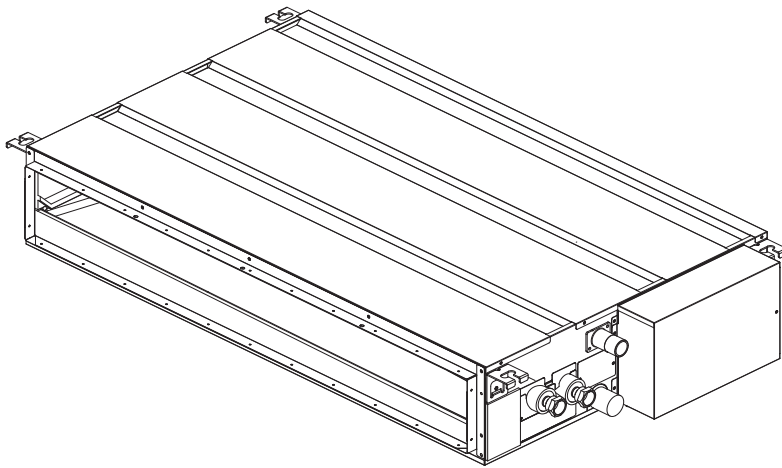

Model	Cooling capacity/Heating capacity
	kW
PEFY-WP10VMS1-E	1.2/1.4
PEFY-WP15VMS1-E	1.7/1.9
PEFY-WP20VMS1-E	2.2/2.5
PEFY-WP25VMS1-E	2.8/3.2
PEFY-WP32VMS1-E	3.6/4.0
PEFY-WP40VMS1-E	4.5/5.0
PEFY-WP50VMS1-E	5.6/6.3

---

## [1] Components and Functions

---

### 1. Indoor (Main) Unit

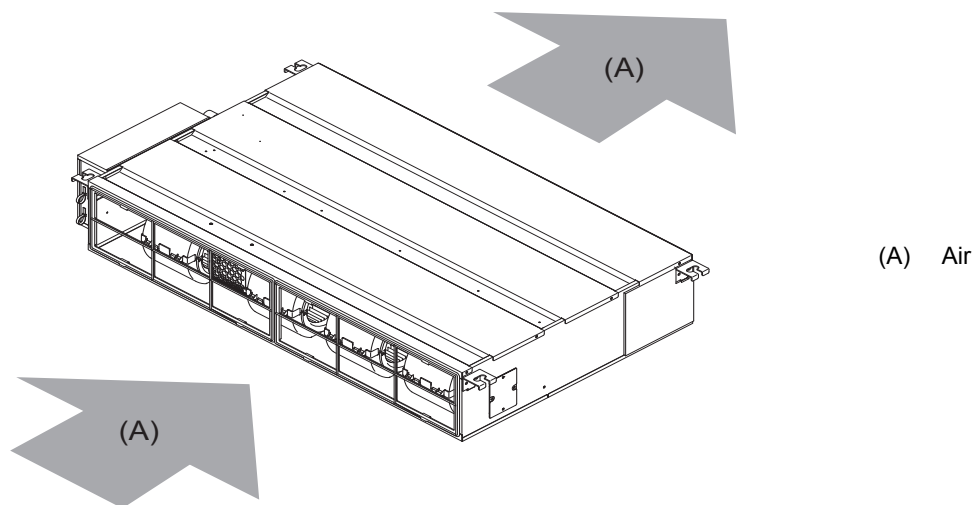

**[1] Specifications**

**1. Specifications**

Model			PEFY-WP10VMS1-E	PEFY-WP15VMS1-E	PEFY-WP20VMS1-E	PEFY-WP25VMS1-E
Power supply	Voltage	V	220-240			
	Frequency	Hz	50/60			
Cooling capacity *1		kW	1.2	1.7	2.2	2.8
Heating capacity *1		kW	1.4	1.9	2.5	3.2
Power consumption *2	Cooling	kW	0.030	0.050	0.051	0.060
	Heating	kW	0.030	0.030	0.031	0.040
Current consumption *2	Cooling	A	0.22	0.44	0.49	0.51
	Heating	A	0.21	0.33	0.38	0.40
External finish (Munsel No.)			Galvanized			
Dimensions	Height	mm	200			
	Width	mm	790			
	Depth	mm	700			
Net weight		kg	19		20	
Heat exchanger			Cross fin (Aluminium fin and copper tube)			
Fan	Type		Sirocco fan x 2			
	Airflow rate (Low-Mid-High)	m <sup>3</sup> /min	4.0-4.5-5.0	5.0-6.0-7.0	5.5-6.5-8.0	5.5-7.0-9.0
	External static pressure	Pa	5/15/35/50	5/15/35/50	5/15/35/50	5/15/35/50
Motor	Output	kW	0.096			
Air filter			PP Honeycomb fabric (washable)			
Diameter of water pipe	Inlet	in	Rc3/4 screw			
	Outlet	in	Rc3/4 screw			
Drain pipe dimensions		mm [in.]	O.D. 32 [1-1/4]			
Operating noise (Low-Mid-High)	5Pa	dB (A)	20-21-22	22-24-26	22-25-28	23-25-29
	15Pa		20-23-25	22-24-28	22-25-29	24-26-30
	35Pa		23-24-25	24-26-29	25-27-30	25-28-31
	50Pa		23-25-27	24-27-30	25-28-32	25-29-33

\*1 <Cooling> Indoor temperature: 27°CDB/19°CWB (81°FDB/66°FWB) Outdoor temperature: 35°CDB (95°FDB)  
 <Heating> Indoor temperature: 20°CDB (68°FDB) Outdoor temperature: 7°CDB/6°CWB (45°FDB/43°FWB)

\*2 The external static pressure is set to 15Pa at factory shipment.

[ III Specifications ]

Model			PEFY-WP32VMS1-E	PEFY-WP40VMS1-E	PEFY-WP50VMS1-E
Power supply	Voltage	V	220-240		
	Frequency	Hz	50/60		
Cooling capacity *1		kW	3.6	4.5	5.6
Heating capacity *1		kW	4.0	5.0	6.3
Power consumption	Cooling	kW	0.071	0.090	0.090
	Heating	kW	0.051	0.070	0.070
Current consumption	Cooling	A	0.61	0.73	0.77
	Heating	A	0.50	0.62	0.66
External finish (Munsel No.)			Galvanized		
Dimensions	Height	mm	200		
	Width	mm	990	1190	
	Depth	mm	700		
Net weight		kg	25	27	
Heat exchanger			Cross fin (Aluminium fin and copper tube)		
Fan	Type		Sirocco fan x 3		Sirocco fan x 4
	Airflow rate (Low-Mid-High)	m <sup>3</sup> /min	8.0-9.5-11.0	9.5-11.0-13.0	12.0-14.0-16.5
	External static pressure	Pa	5/15/35/50	5/15/35/50	5/15/35/50
Motor	Output	kW	0.096		
Air filter			PP Honeycomb fabric (washable)		
Diameter of water pipe	Inlet	in	Rc3/4 screw		
	Outlet	in	Rc3/4 screw		
Drain pipe dimensions		mm [in.]	O.D. 32 [1-1/4]		
Operating noise (Low-Mid-High)	5Pa	dB (A)	26-29-32	29-31-34	29-32-35
	15Pa		28-30-33	30-32-35	30-33-36
	35Pa		30-32-35	31-34-37	31-35-39
	50Pa		31-33-36	32-34-38	32-36-40

\*1 <Cooling> Indoor temperature: 27°CDB/19°CWB (81°FDB/66°F WB Outdoor temperature: 35°CDB (95°FDB)  
 <Heating> Indoor temperature: 20°CDB (68°FDB) Outdoor temperature: 7°CDB/6°CWB (45°FDB/43°F WB)



## 2. Electrical component specifications

Component	Sym- bol	PEFY- WP10VMS1-E	PEFY- WP15VMS1-E	PEFY- WP20VMS1-E	PEFY- WP25VMS1-E
Room temperature thermistor	TH21	Resistance 0°C/15kΩ, 10°C/9.6kΩ, 20°C/6.3kΩ, 25°C/5.4kΩ, 30°C/4.3kΩ, 40°C/3.0kΩ			
Water inlet pipe thermistor	TH22	Resistance 0°C/15kΩ, 10°C/9.6kΩ, 20°C/6.3kΩ, 25°C/5.4kΩ, 30°C/4.3kΩ, 40°C/3.0kΩ			
Water outlet pipe thermistor	TH23	Resistance 0°C/15kΩ, 10°C/9.6kΩ, 20°C/6.3kΩ, 25°C/5.4kΩ, 30°C/4.3kΩ, 40°C/3.0kΩ			
Fuse	FUSE	250V 6.3A			
Fan motor		8-pole, Output 96W SIC-70CW-D8114-1			
Power supply terminal block	TB2	(L, N, ⊕) 330V 30A			
Transmission terminal block	TB5 TB15	(1, 2), (M1, M2, S) 250V 20A			
Drain float switch	DS	Open/short detection Initial contact resistance 500 mΩ or less			

Component	Sym- bol	PEFY-WP32VMS1-E	PEFY-WP40VMS1-E	PEFY-WP50VMS1-E
Room temperature thermistor	TH21	Resistance 0°C/15kΩ, 10°C/9.6kΩ, 20°C/6.3kΩ, 25°C/5.4kΩ, 30°C/4.3kΩ, 40°C/3.0kΩ		
Water inlet pipe thermistor	TH22	Resistance 0°C/15kΩ, 10°C/9.6kΩ, 20°C/6.3kΩ, 25°C/5.4kΩ, 30°C/4.3kΩ, 40°C/3.0kΩ		
Water outlet pipe thermistor	TH23	Resistance 0°C/15kΩ, 10°C/9.6kΩ, 20°C/6.3kΩ, 25°C/5.4kΩ, 30°C/4.3kΩ, 40°C/3.0kΩ		
Fuse	FUSE	250V 6.3A		
Fan motor		8-pole, Output 96W SIC-70CW-D896-2		
Power supply terminal block	TB2	(L, N, ⊕) 330V 30A		
Transmission terminal block	TB5 TB15	(1, 2), (M1, M2, S) 250V 20A		
Drain float switch	DS	Open/short detection Initial contact resistance 500 mΩ or less		

[1] Outlines and Dimensions

1. PEFY-WP10, 15, 20, 25, 32, 40, 50VMS1-E

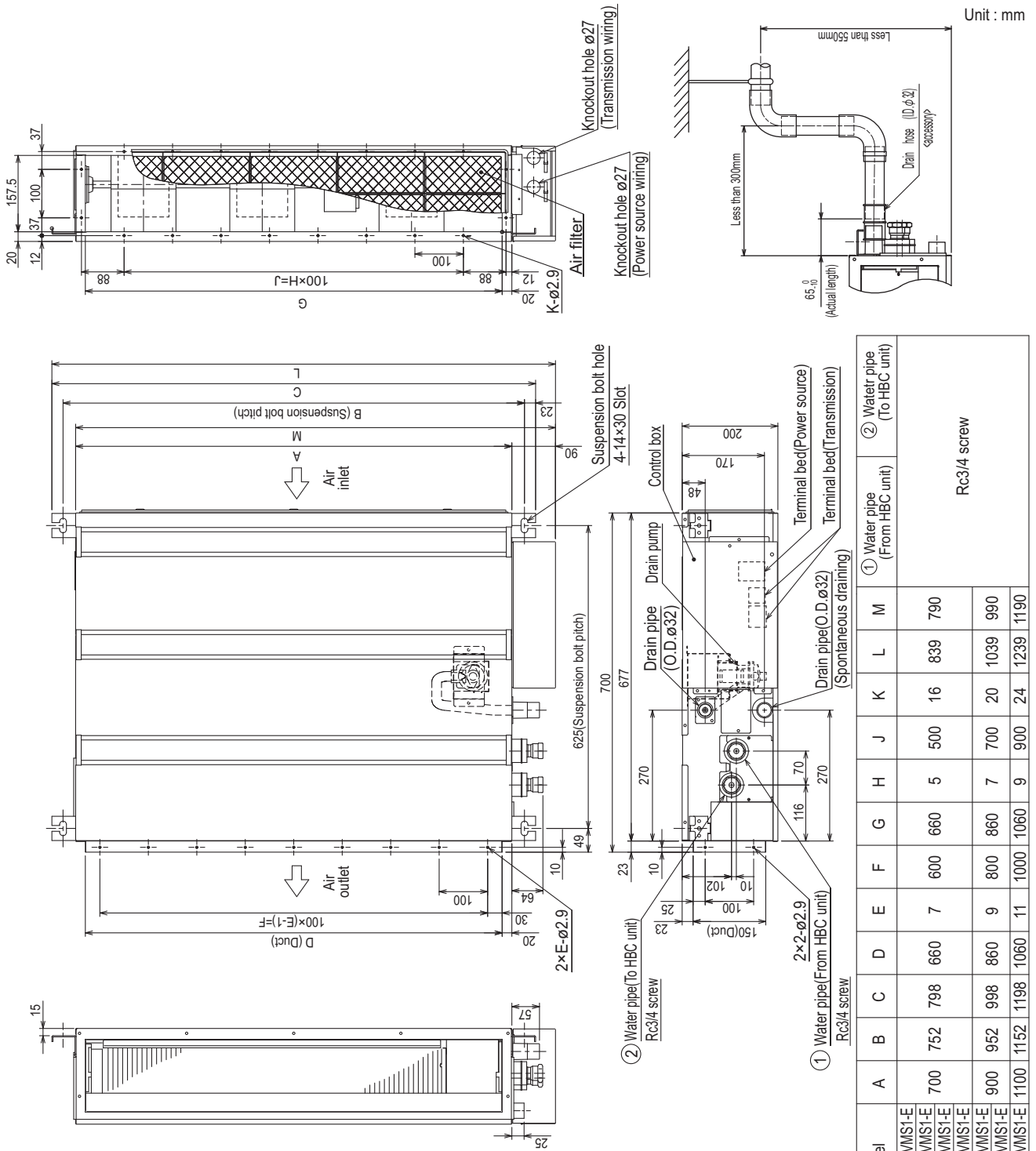

Model	A	B	C	D	E	F	G	H	J	K	L	M
PEFY-WP10VMS1-E	700	752	798	660	7	600	660	5	500	16	839	790
PEFY-WP15VMS1-E	900	952	998	860	9	800	860	7	700	20	1039	990
PEFY-WP20VMS1-E	1100	1152	1198	1060	11	1000	1060	9	900	24	1239	1190

- (A) Space required for service and maintenance.
- (B) Provide an access door for maintenance at the bottom.

Note

- 1 Use M10 screw for the suspension bolt (field supply).
- 2 Keep the service space for the maintenance at the bottom.
- 3 This chart indicates for PEFY-WP32, 40VMS1-E models, which has 3 fans.  
PEFY-WP10, 15, 20, 25VMS1-E models have 2 fans.  
PEFY-WP50VMS1-E models have 4 fans.

4 In case an inlet duct is used, remove the air filter (supply with the unit), then install the filter (field supply) at suction side.

[Maintenance access space]

Secure enough access space to allow for the maintenance, inspection, and replacement of the motor, fan, drain pump, heat exchanger, and electric box in one of the following ways.  
 Select an installation site for the indoor unit so that its maintenance access space will not be obstructed by beams or other objects.

(1) When a space of 300mm or more is available below the unit between the unit and the ceiling. (Fig.1)

-Create access door 1 and 2 (450x450mm each) as shown in Fig.2.

(Access door 2 is not required if enough space is available below the unit for a maintenance worker to work in.)

(2) When a space of less than 300mm is available below the unit between the unit and the ceiling.

(At least 20mm of space should be left below the unit as shown in Fig.3.)

-Create access door 1 diagonally below the electric box and access door 3 below the unit as shown in Fig.4.

or

-Create access door 4 below the electric box and the unit as shown in Fig.5.

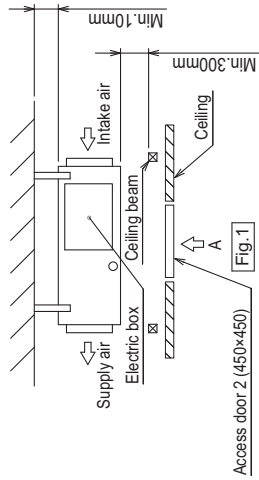

[Fig.1]

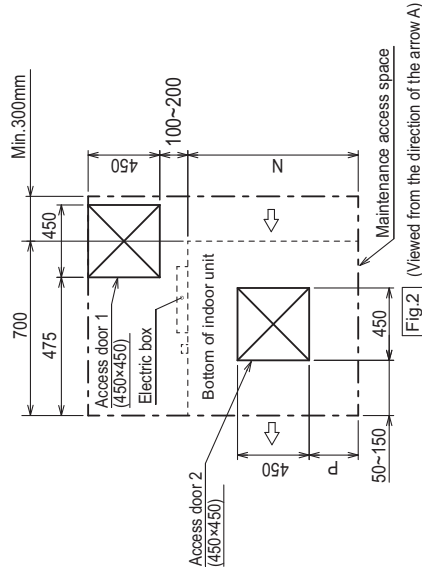

[Fig.2]

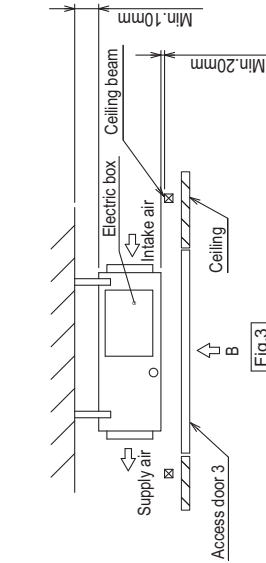

[Fig.3]

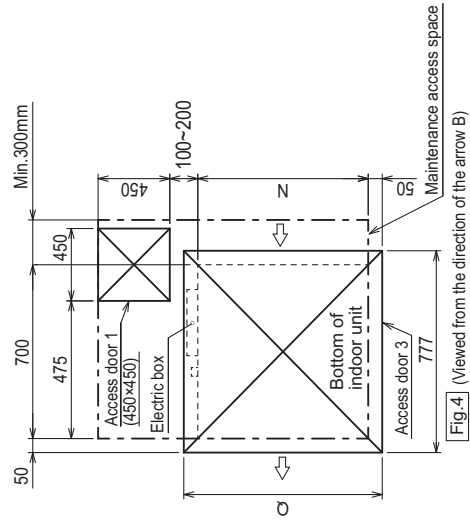

[Fig.4]

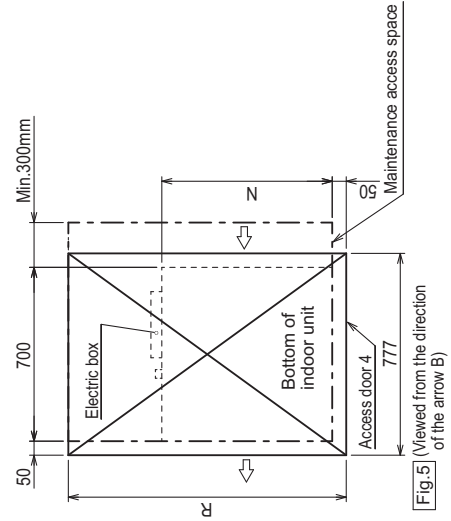

[Fig.5]

Model	N	P	Q	R
PEFY-WP10VMS1-E	700	50~150	800	1300
PEFY-WP15VMS1-E	700	50~150	800	1300
PEFY-WP20VMS1-E	700	50~150	800	1300
PEFY-WP25VMS1-E	900	150~250	1000	1500
PEFY-WP32VMS1-E	900	150~250	1000	1500
PEFY-WP40VMS1-E	1100	250~350	1200	1700
PEFY-WP50VMS1-E	1100	250~350	1200	1700

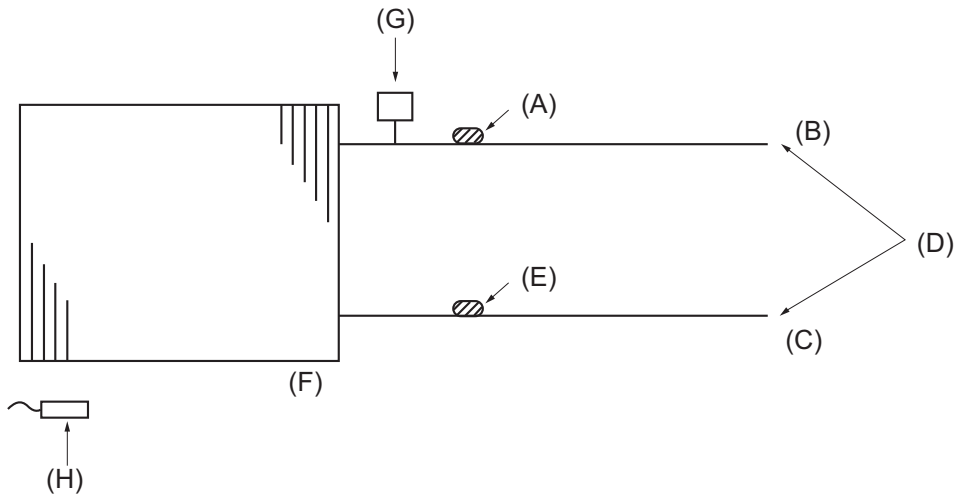

Table.1 SYMBOL EXPLANATION

SYM-BOL	NAME	SYM-BOL	NAME	SYM-BOL	NAME
I.B.	Indoor control board	CN32	Connector (Remote switch)	SW3 (I.B.)	Switch (function setting)
A.B.	Address board	CN41	Connector (HA terminal-A)	SW4 (I.B.)	Switch (function setting)
TB2	Power supply terminal block	CN51	Connector (Centralized control)	SWE (I.B.)	Connector (emergency operation)
TB5	Transmission terminal block	CN52	Connector (Remote display)	SW1 (A.B.)	Switch (function setting)
TB15	Transmission terminal block	CN90	Connector (Wireless)	SW11 (A.B.)	Switch (For setting the 1's digit in the address)
FUSE	Fuse AC 250V 6.3A	CN100	Connector (IT terminal)	SW12 (A.B.)	Switch (For setting the 10's digit in the address)
ZNR01, 02	Varistor	FS	Float switch	SW14 (A.B.)	Switch (connection No.setting)
DSA	Arrester	TH21	Thermistor (inlet air)	SWA (A.B.)	Switch (static pressure setting)
X1	Aux. relay	TH22	Thermistor (water in)	SWB (A.B.)	Switch (function setting)
L1	AC reactor (Power factor improvement)	TH23	Thermistor (water out)	SWC (A.B.)	Switch (static pressure setting)
CN27	Connector (Damper)	SW2 (I.B.)	Switch (capacity code setting)		

- Note 1 Wiring to TB2, TB5, and TB15 indicated by the double-dashed lines is on-site work.  
 2 ◎ terminal block, ⊖ connector.

**[1] Refrigerant system diagram**



- (A) Water outlet thermistor TH23
- (B) Water outlet
- (C) Water inlet
- (D) Screw connections
- (E) Water inlet thermistor TH22
- (F) Heat exchanger
- (G) Manual air purge valve
- (H) Room temperature thermistor TH21

Capacity	PEFY-WP10, 15, 20, 25, 32, 40, 50VMS1-E
Water outlet	Rc3/4 screw
Water inlet	Rc3/4 screw

## [1] Troubleshooting

### 1. Check methods

1. Component and check points

(1) Thermistor

- Room temperature thermistor (TH21)
- Water inlet thermistor (TH22)
- Water outlet thermistor (TH23)

Disconnect the connector and measure the resistance between terminals with a tester.  
(Ambient temperature 10°C - 30°C)

Normal	Abnormal
4.3kΩ - 9.6kΩ	Open or short

(Refer to the thermistor characteristic graph below.)

1) Thermistor characteristic graph

**Low-temperature thermistor**

- Room temperature thermistor (TH21)
- Water inlet pipe thermistor (TH22)
- Water outlet pipe thermistor (TH23)
- Drain sensor (DS)

- Thermistor  $R_0 = 15\text{ k}\Omega \pm 3\%$
- Multiplier of B =  $3480\text{ k}\Omega \pm 2\%$

$$R_t = 15 \exp \left\{ 3480 \left( \frac{1}{273+t} - \frac{1}{273} \right) \right\}$$

- 0°C 15kΩ
- 10°C 9.6kΩ
- 20°C 6.3kΩ
- 25°C 5.2kΩ
- 30°C 4.3kΩ
- 40°C 3.0kΩ

- (A) Temperature (°C)
- (B) Resistance (kΩ)

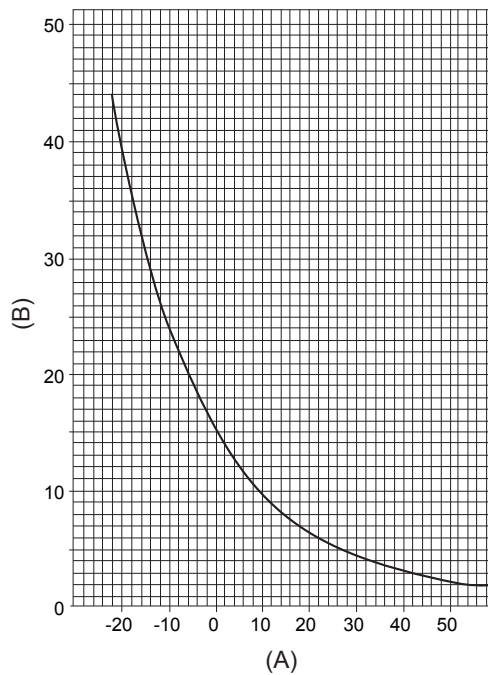

(2) Fan motor (CNMF)

Refer to the page on "DC fan motor (fan motor/indoor control board)."

(3) Drain-up mechanism

Measure the resistance between the terminals with a tester.  
(coil temperature 20°C)

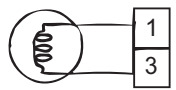
	Normal	Abnormal
	340 Ω	Open or short

(4) Drain float switch (CN4F)

Disconnect the connector, and measure the resistance between terminals with a tester.

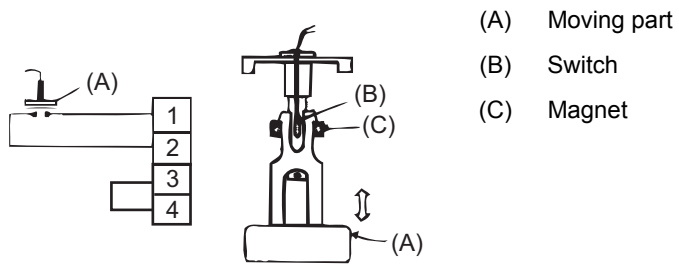

Position of the moving part	Normal	Abnormal
Up	Short	(any position but short)
Down	Open	(any position but open)



## 2. DC fan motor (fan motor/indoor control board)

### 1. CAUTION

- A high voltage is applied to the connector for connection to the fan motor (CNMF).
- Do not unplug the connector CNMF with the unit energized to avoid damage to the indoor control board and fan motor.

### 2. Troubleshooting

- Symptom: Indoor unit fan does not run.

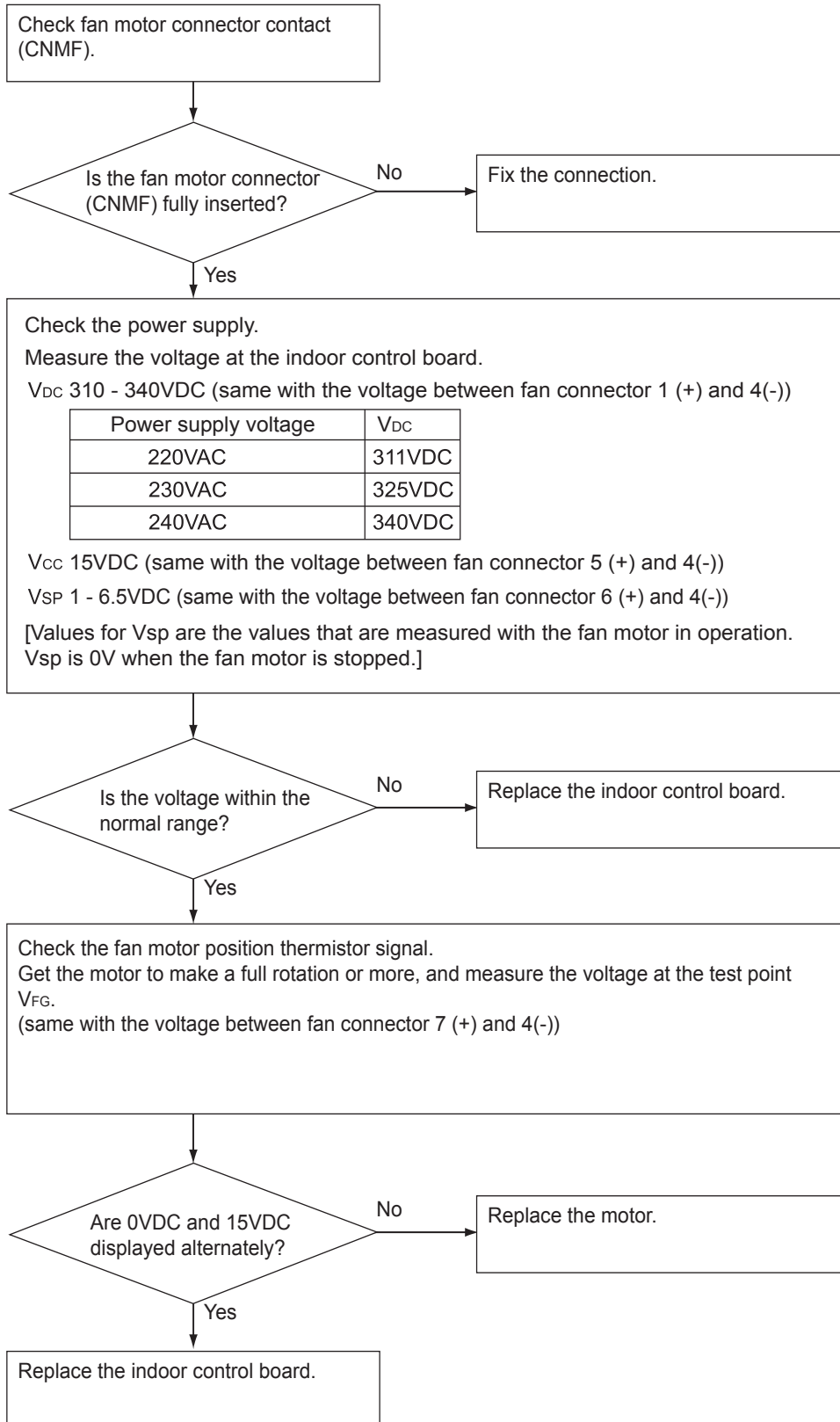

### 3. Address switch setting

Make sure that power to the unit is turned off.

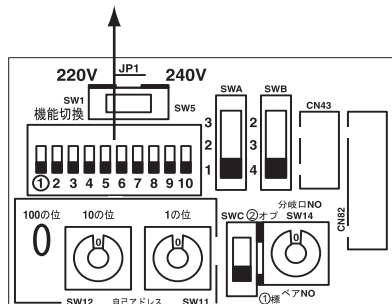
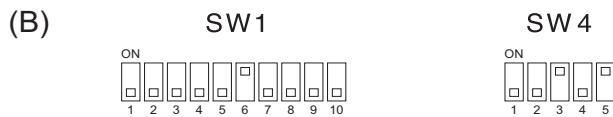
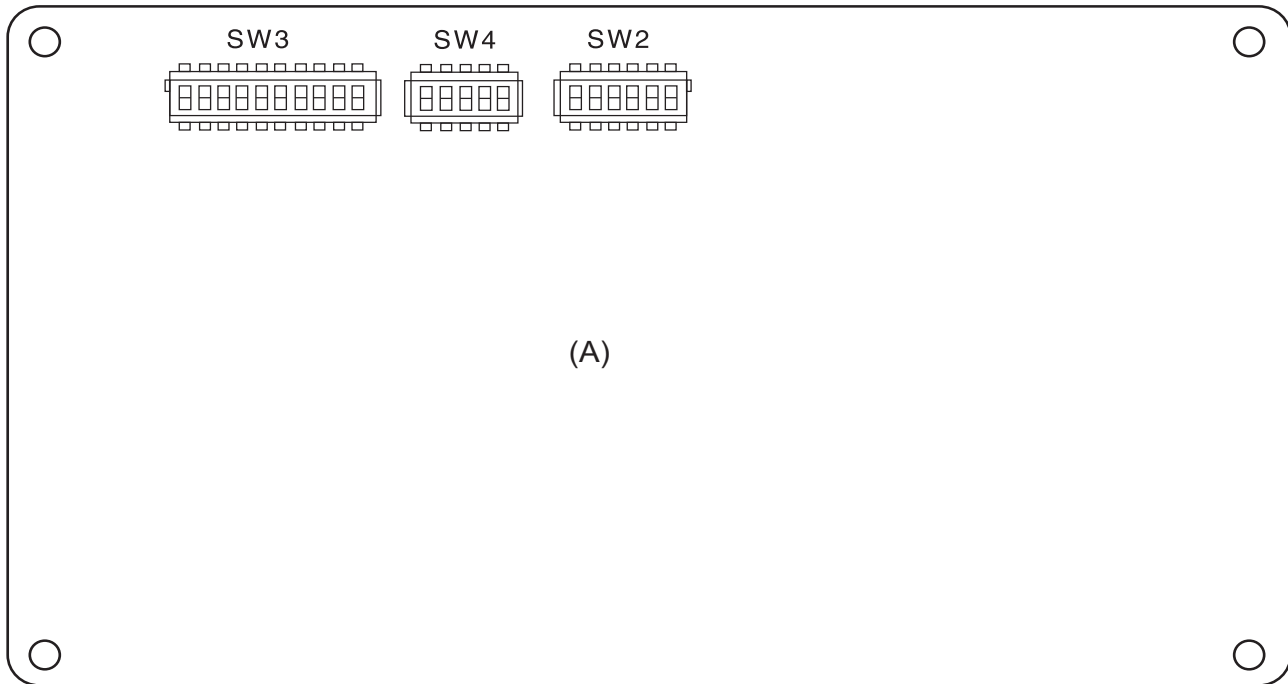

(A) Indoor unit control board  
 (B) Factory setting (all models)

1. When using an ME remote controller, set the address with the rotary switches (SW11, SW12).  
 •Address setting is not required when the unit remote controller is used.  
**On-site address setting is required for the indoor units to run.**
2. Address settings vary in different systems.  
 Refer to the section on address setting in the outdoor unit installation manual.
3. Address is set with a combination of SW12 (10's digit) and SW11 (1's digit).  
 To set the address to "3," set SW12 to "0" and SW11 to "3."  
 To set the address to "25," set SW 12 to "2" and SW 11 to "5."

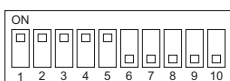

The figure at left shows that the switches 1 through 5 are set to ON and 6 through 10 are set to OFF.

### 4. Voltage test points on the control board

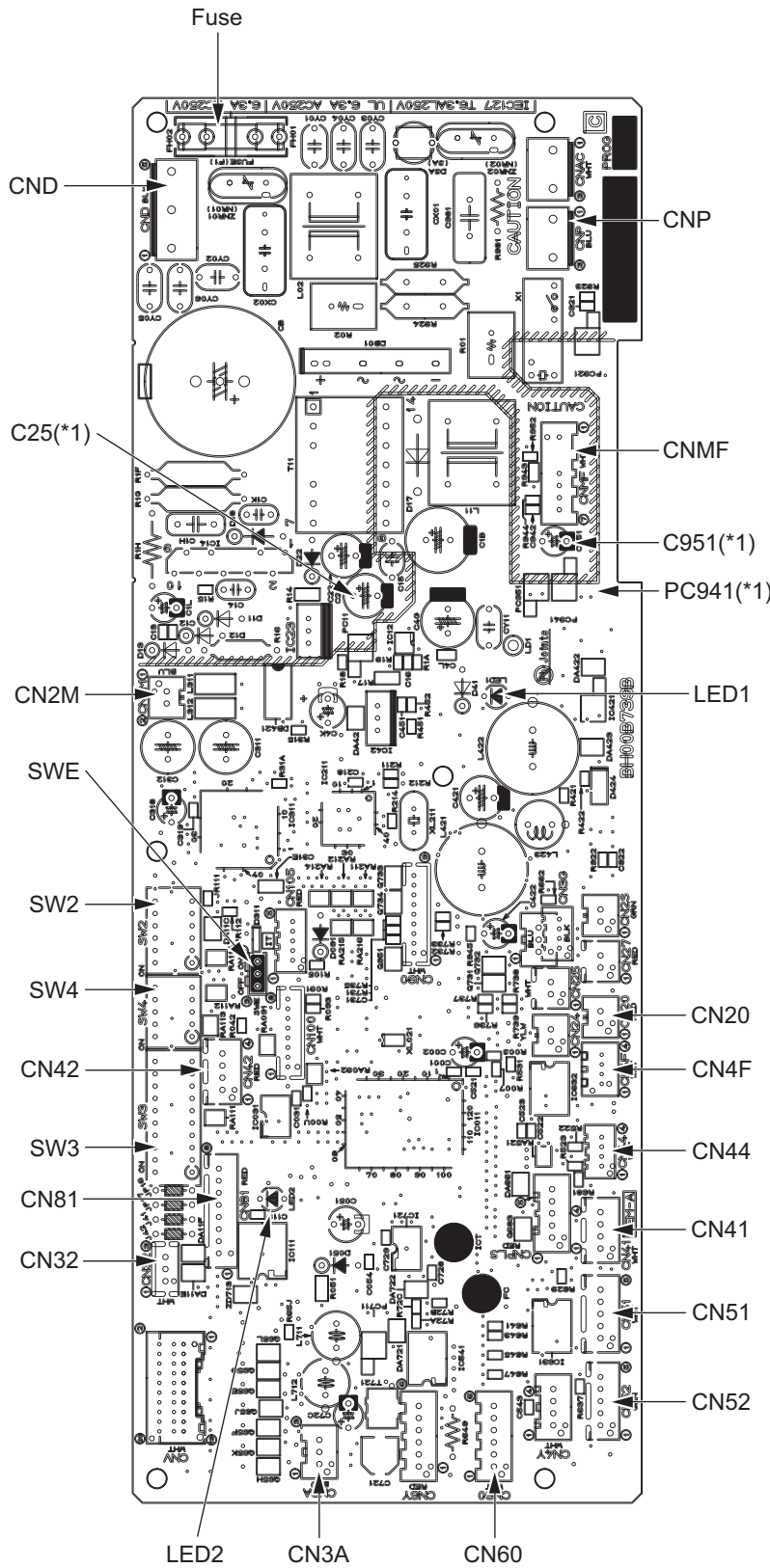

- Fuse Fuse(AC 250V 6.3A)
- CND Power supply voltage (220 - 240VAC)
- CN2M For M-NET transmission cable connection (24 - 30VDC)
- SWE Emergency operation
- SW2 Capacity setting
- SW4 Function setting
- CN42 For address board connection
- SW3 Function setting
- CN81 For address board connection
- CN32 Remote start/stop adapter
- CN3A For MA remote controller cable connection (10 - 13 VDC (Between 1 and 3.))
- CN52 Remote display
- CN51 Centralized control
- CN41 JAMA standard HA terminal A
- CN44 Thermistor (water inlet/water outlet temperature)
- CN4F Float thermistor
- CN20 Thermistor (Inlet temperature)
- CNMF Fan motor output  
 1 - 4: 310 - 340 VDC  
 5 - 4: 15 VDC  
 6 - 4: 0 - 6.5 VDC  
 7 - 4: Stop 0 or 15 VDC  
 Run 7.5 VDC (0 - 15 pulse)
- CNP Drain-up mechanism output (200VAC)
- (\*1)
- V<sub>FG</sub> Voltage on the (-) side of PC941 and C25 (Same with the voltage between 7 (+) and 4 (-) of CNMF)
- V<sub>CC</sub> Voltage between the C25 pins 15 VDC (Same with the voltage between 5 (+) and 4 (-) of CNMF)
- V<sub>sp</sub> Voltage between the C951 pins 0VDC (with the fan stopped) 1 - 6.5VDC (with the fan in operation) (Same with the voltage between 6 (+) and 4 (-) of CNMF)

### 5. Dipswitch setting (Factory setting)

1. Function setting

(1) SW1

Switch position	Function	Switch setting	
		ON	OFF
1	Active Thermistor (Intake air thermistor)	Built-in thermistor on the remote controller	Indoor unit
2	Filter clogging detection	Available	Unavailable
3	Filter life	2500 hr	100 hr
4	Outdoor air intake	Enabled	Disabled
5	Remote display	Thermo-ON signal	Fan output
6	Humidifier operation	During heating mode	During heating operation
7	Fan speed	Low	Very low
8	Fan speed at heating Thermo-OFF	Preset fan speed	Follows the setting of SW1-7
9	Auto restart after power failure	Enabled	Disabled
10	Power start/stop	Enabled	Disabled

1) Address board

Factory setting

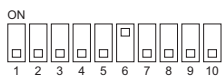

(2) SW3

Switch position	Function	Switch setting	
		ON	OFF
1	Unit type	Cooling only	Heat pump
2	-	-	-
3	-	-	-
4	-	-	-
5	-	-	-
6	-	-	-
7	-	-	-
8	Heating 4-deg up	Disabled	Enabled

1) Indoor control board

Dipswitch settings must be made while the unit is stopped.

Factory setting

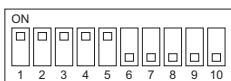

The figure at left shows that the switches 1 through 5 are set to ON and 6 through 10 are set to OFF.

[ VII Troubleshooting ]

2. Capacity code setting

(1) SW2

1) Indoor control board

Dipswitch settings must be made while the unit is stopped.

Factory setting

The switches are set to correspond to the unit capacity.

PEFY-WP10VMS1-E    PEFY-WP15VMS1-E    PEFY-WP20VMS1-E    PEFY-WP25VMS1-E

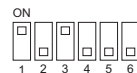

PEFY-WP32VMS1-E    PEFY-WP40VMS1-E    PEFY-WP50VMS1-E



3. Model setting

(1) SW4

1) Indoor control board

Dipswitch settings must be made while the unit is stopped.

Factory setting

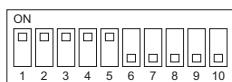

The figure at left shows that the switches 1 through 5 are set to ON and 6 through 10 are set to OFF.

Note:

Changes made to the dipswitches SW1, SW2, and SW3 will become effective when the unit comes to a stop (remote controller off). There is no need to power cycle the unit.

4. External static pressure

(1) SWA, SWC

1) Address board

All models

5Pa		15Pa		35Pa		50Pa	
3 2 1	②オフ ①標	3 2 1	②オフ ①標	3 2 1	②オフ ①標	3 2 1	②オフ ①標
SWA	SWC	SWA	SWC	SWA	SWC	SWA	SWC

Factory setting

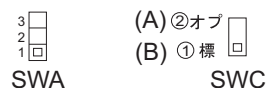

- (A) Option
- (B) Standard



The figure at left shows that the switch is set to 1.

Note:

Changes that are made to the dipswitches SWA and SWC immediately become effective regardless of the unit's operation status (RUN/STOP) or the remote controller status (ON/OFF).

5. 1's and 10's digits

(1) SW11, SW12 (Rotary switch)

The use of a network remote controller (PAR-F27MEA) requires address setting.

1) Address board

Address settings must be made while the unit is stopped.

Factory setting

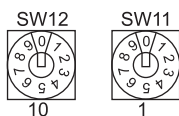

6. Connection No. setting

(1) SW14 (Rotary switch)

This switch is used when the unit connected to an R2 series of outdoor unit.

1) Address board

Factory setting



Note:

Changes to the dipswitches SW11, SW12, SW14, and SW15 must be made while the unit is stopped and the remote controller is OFF.

**6. Instructions for debris removal operation**

Details are described in section [9] "Instructions for debris removal operation" under chapter IX Troubleshooting in the Service Handbook for the HBC.

Refer to the figure below for the position of the air vent valve on the indoor unit.

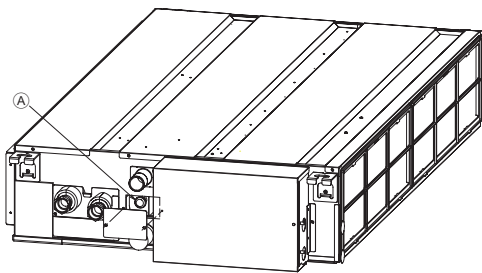

Ⓐ Air vent valve

**7. Instructions for the air vent operation**

Details are described in section [9] "Instructions for debris removal operation" under chapter IX Troubleshooting in the Service Handbook for the HBC.

Refer to the figure below for the position of the air vent valve on the indoor unit.

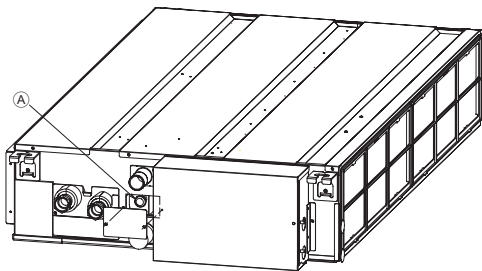

Ⓐ Air vent valve

---

## [1] Disassembly Procedure

---

### 1. Control box

Exercise caution when removing heavy parts.

1. Removing the control box cover
  - (1) Remove the two fixing screws on the cover (A) to remove it.

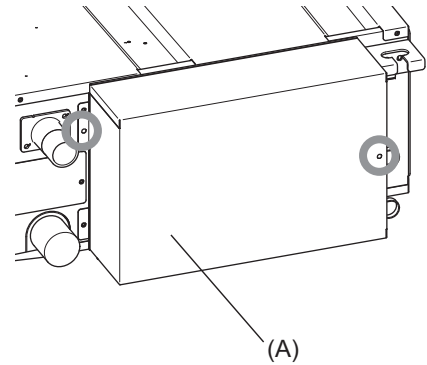

Fig.1

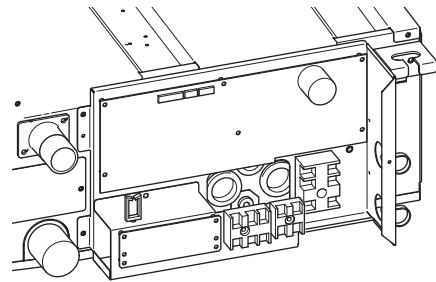

Fig.2

## 2. Thermistor (Intake air)

Exercise caution when removing heavy parts.

1. Remove the control box cover according to the procedure in **section 1**.
2. Remove the thermistor.
  - (1) Remove the two fixing screws on the metal base (B) to remove it.

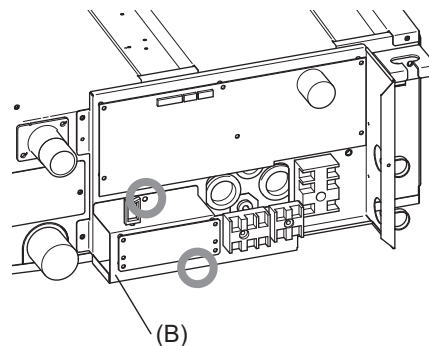

Fig.3

- (2) Pull out the thermistor holder (C) and thermistor (D) on the control box.

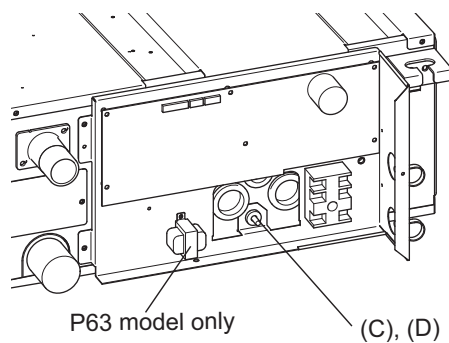

Fig.4



### 3. Drainpan

Exercise caution when removing heavy parts.

1. Removing the filter and the bottom plate
  - (1) Push down the tab on the filter, and pull out the filter in the direction of the arrow 1.
  - (2) Remove the fixing screws on the bottom plate (D), (E) to remove it.

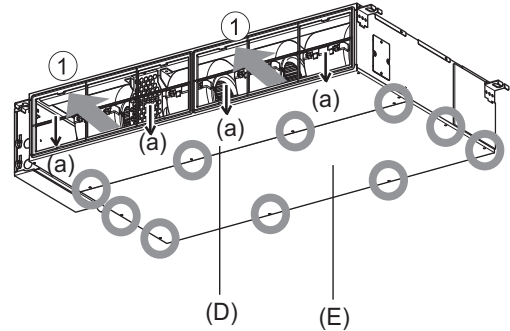

Fig.5

2. Removing the drainpan
  - (1) Pull out the drain pan in the direction of the arrow 1.

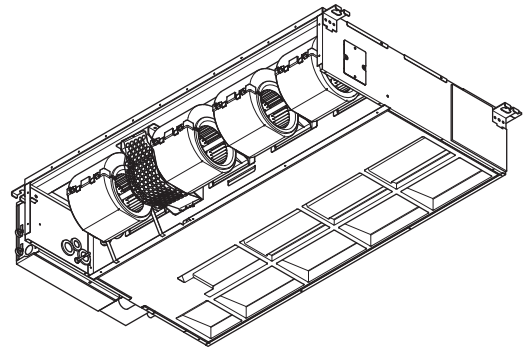

Fig.6

**Note**  
♦Drain the water out of the drain pan before removing it.  
♦To avoid dew condensation, use insulated screws in the places marked with circles in Figure 7.

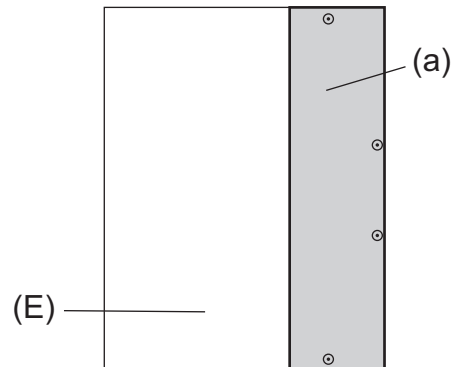

Fig.7

(a) Insulation material

#### 4. Thermistor (Water outlet) (Water inlet)

Exercise caution when removing heavy parts.

1. Remove the drain pan according to the procedure in **section 3**.
2. Removing the Heat exchanger cover
  - (1) Remove the four fixing screws on the heat exchanger cover (F) to remove it.

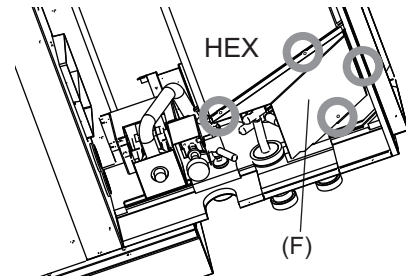

Fig.8

3. Removing the thermistor
  - (1) Remove the thermistor (G) from the thermistor holder (H) on the copper tube.

Thermistor size  
Water in:  $\varnothing 8\text{mm}$   
Water out:  $\varnothing 6\text{mm}$

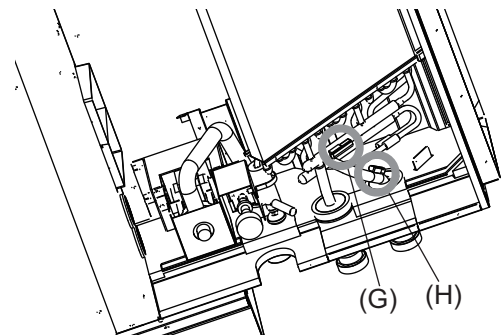

Fig.9

### 5. Fan and fan motor

Exercise caution when removing heavy parts.

1. Removing the filter and the bottom plate
  - (1) Push down the tab on the filter, and pull out the filter in the direction of the arrow 1.
  - (2) Remove the fixing screws on the bottom plate (J) to remove it.

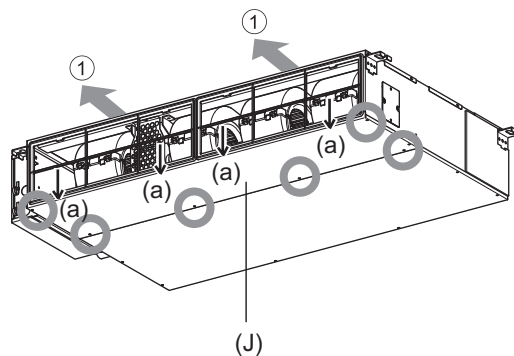

Fig.10

(a) Tab

2. Removing the punching metal
  - (1) Remove the two fixing screws on the punching metal (K) to remove it.
3. Removing the fan casing (bottom half)
  - (1) Squeeze the tabs on the fan casing to remove it in the direction of arrow 2.

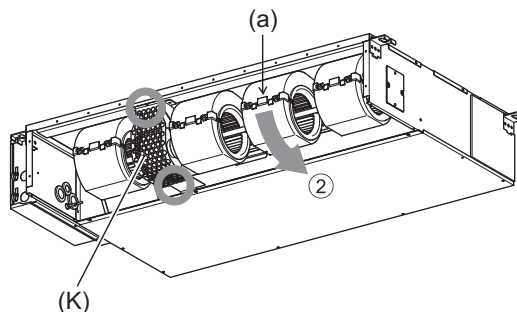

Fig.11

4. Removing the motor cable
  - (1) Remove the motor cable through the rubber bush.
5. Removing the fan motor and the Sirocco fan
  - (1) Remove the two motor fixing screws to remove the motor and the Sirocco fan in the direction of arrow 3.

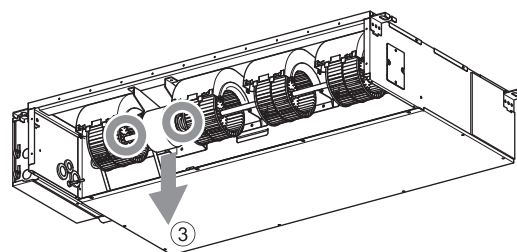

Fig.12

- (2) Remove the four fan case fixing screws to take the top half of the fan casing off.

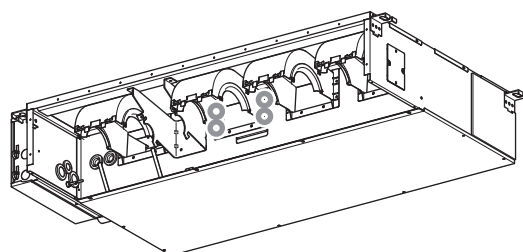

Fig.13

## 6. Bearing

P40, P50, P63 models only.

Exercise caution when removing heavy parts.

1. Removing the bearing
  - (1) Remove the two fixing screws on the bearing cover (M) to remove it.

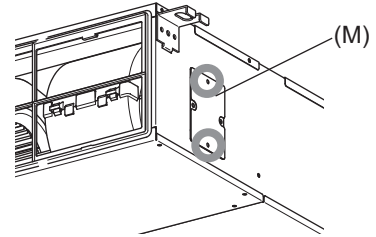

Fig.14

- (2) Remove the two bearing retainer screws to remove the bearing.

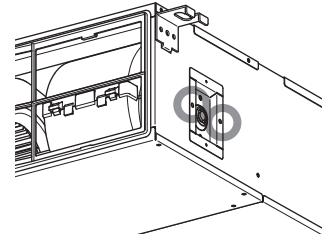

Fig.15

## 7. Heat exchanger

Exercise caution when removing heavy parts.

1. Remove the drain pan according to the procedure in **section 3**.
2. Remove the heat exchanger cover according to the procedure in **section 4 2**.
3. Removing the cover
  - (1) Remove the two fixing screws on the cover (T) to remove it.

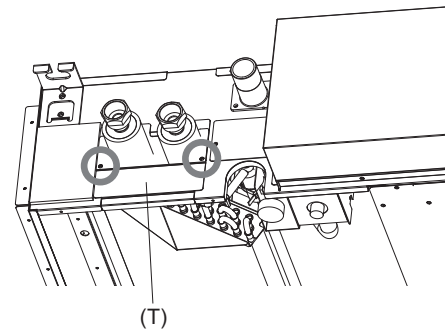

Fig.16

(T) Pipe support plate

4. Removing the Heat exchanger
  - (1) Remove the fixing screws on the heat exchanger (S) to remove it.

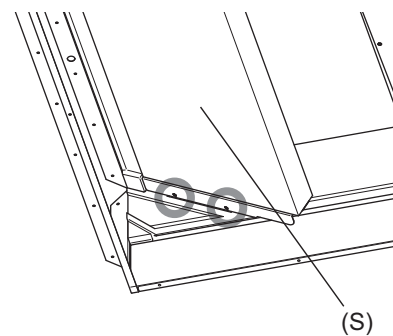

Fig.17

## 8. Drain pump

Exercise caution when removing heavy parts.

1. Remove the drain pan according to the procedure in **section 3**.
2. Removing the air-vent pipe
  - (1) Remove the air-vent pipe (a) from the cable strap (b).

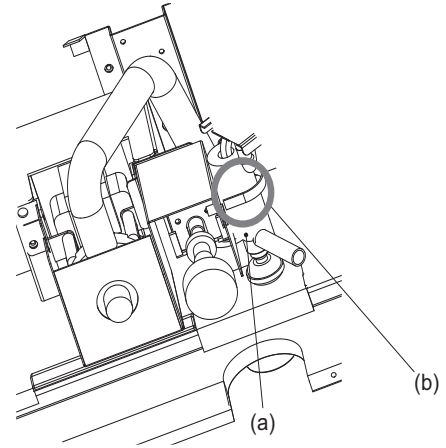

Fig.18

3. Removing the drain pump
  - (1) Remove the four screws that are holding the drain pump and the float switch in place.

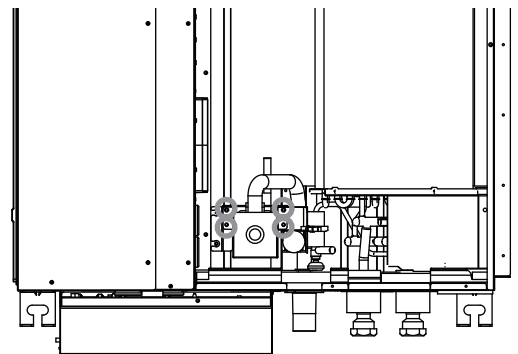

Fig.19

## 9. Float Switch

Exercise caution when removing heavy parts.

1. Remove the drain pan according to the procedure in **section 3**.
2. Removing the air-vent pipe
  - (1) Remove the air-vent pipe (a) from the cable strap (b).

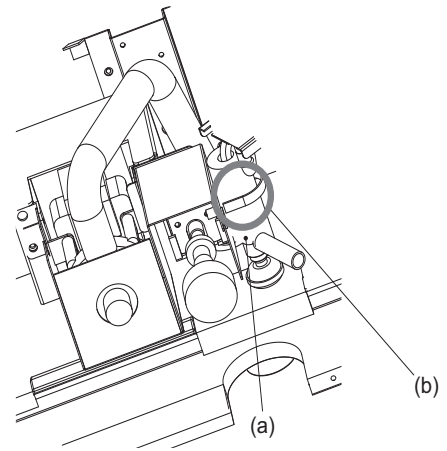

Fig.20

3. Removing the drain pump
  - (1) Remove the four screws that are holding the drain pump and the float switch in place.

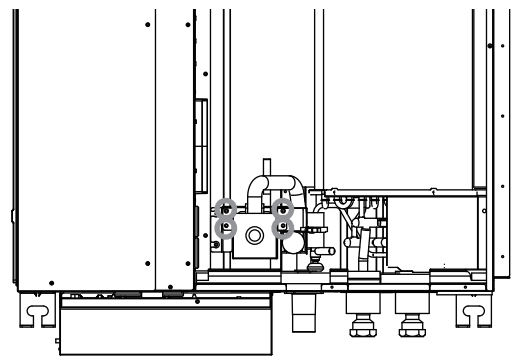

Fig.21

4. Removing the float switch
  - (1) Remove the two screws that are holding the float switch in place.

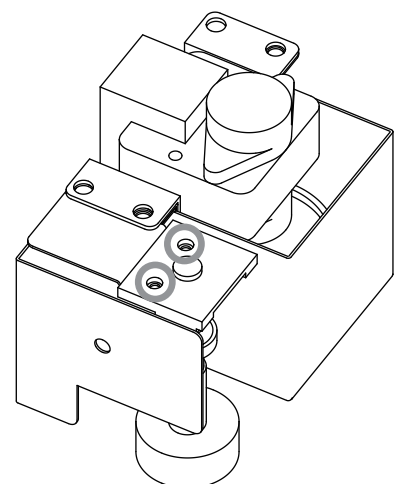

Fig.22

# **mitsubishi electric corporation**

---