

# **TECHNICAL & SERVICE MANUAL**

---

Models **PEFY-P20VMR-E-L/R**  
**PEFY-P25VMR-E-L/R**  
**PEFY-P32VMR-E-L/R**

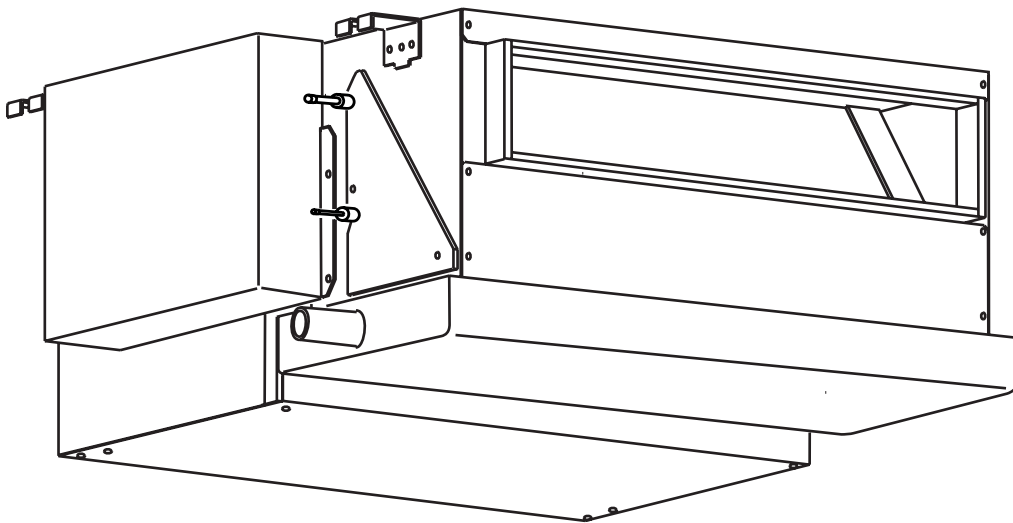

# **CITY MULTI**

**For use with R410A**

# SAFETY PRECAUTIONS





## 1. Read before installation and performing electrical work

- Thoroughly read the following safety precautions prior to installation.
- Observe these safety precautions for your safety.
- This equipment may have adverse effects on the equipment on the same power supply system.
- Contact the local power authority before connecting to the system.

### Symbol explanations

 **WARNING**  
This symbol indicates that failure to follow the instructions exactly as stated poses the risk of serious injury or death.

 **CAUTION**  
This symbol indicates that failure to follow the instructions exactly as stated poses the risk of serious injury or damage to the unit.

-  : Indicates an action that must be avoided.
-  : Indicates important instructions.
-  : Indicates a parts that requires grounding.
-  : Indicates that caution must be taken with rotating parts. (This symbol is on the main unit label.) <Color: Yellow>
-  : Indicates that the parts that are marked with this symbol pose a risk of electric shock. (This symbol is on the main unit label.) <Color: Yellow>

 **WARNING**  
Carefully read the labels affixed to the main unit.

### WARNING

- Ask your dealer or a qualified technician to install the unit.
- Improper installation by the user may result in water leakage, electric shock, or fire.
- Properly install the unit on a surface that can withstand its weight.
- Unit installed on an unstable surface may fall and cause injury.
- Only use specified cables. Securely connect each cable so that the terminals do not carry the weight of the cable.
- Improperly connected cables may produce heat and start a fire.
- Take appropriate safety measures against wind gusts and earthquakes to prevent the unit from toppling over.
- Improper installation may cause the unit to topple over and cause injury or damage to the unit.
- Only use accessories (i.e., air cleaners, humidifiers, electric heaters) recommended by Mitsubishi Electric.

- Do not make any modifications or alterations to the unit. Consult your dealer for repair.
- Improper repair may result in water leakage, electric shock, or fire.
- Do not touch the heat exchanger fins with bare hands.
- The fins are sharp and pose a risk of cuts.
- In the event of a refrigerant leak, thoroughly ventilate the room.
- If gaseous refrigerant leaks out and comes in contact with an open flame, toxic gases will be generated.
- Properly install the unit according to the instructions in the Installation Manual.
- Improper installation may result in water leakage, electric shock, or fire.
- Have all electrical work performed by an authorized electrician according to the local regulations and the instructions in this manual. Use a dedicated circuit.
- Insufficient power supply capacity or improper installation of the unit may result in malfunctions of the unit, electric shock, or fire.

**⚠ WARNING**

- Keep electrical parts away from water.
- Wet electrical parts pose a risk of electric shock, smoke, or fire.
- Securely attach the control box cover.
- If the cover is not installed properly, dust or water may infiltrate and pose a risk of electric shock, smoke, or fire.
- Only use the type of refrigerant that is indicated on the unit when installing or relocating the unit.
- Infiltration of any other types of refrigerant or air into the unit may adversely affect the refrigerant cycle and may cause the pipes to burst or explode.
- When installing the unit in a small space, take appropriate precautions to prevent leaked refrigerant from reaching the limiting concentration.
- Leaked refrigerant gas will displace oxygen and may cause oxygen starvation. Consult your dealer before installing the unit.

- Consult your dealer or a qualified technician when moving or reinstalling the unit.
- Improper installation may result in water leakage, electric shock, or fire.
- After completing the service work, check for a refrigerant leak.
- If leaked refrigerant is exposed to a heat source, such as a fan heater, stove, or electric grill, toxic gases will be generated.
- Do not try to defeat the safety features of the unit.
- Forced operation of the pressure switch or the temperature switch by defeating the safety features for these devices, or the use of accessories other than the ones that are recommended by Mitsubishi Electric may result in smoke, fire, or explosion.
- Consult your dealer for proper disposal method.
- Do not use a leak detection additive.

**2. Precautions for handling units for use with R410A**

**⚠ CAUTION**

- Do not use the existing refrigerant piping.
- A large amount of chlorine that may be contained in the residual refrigerant and refrigerator oil in the existing piping may cause the refrigerator oil in the new unit to deteriorate.
- Use refrigerant piping materials made of phosphorus deoxidized copper. Keep the inner and outer surfaces of the pipes clean and free of such contaminants as sulfur, oxides, dust, dirt, shaving particles, oil, and moisture.
- Contaminants in the refrigerant piping may cause the refrigerator oil to deteriorate.
- Store the piping materials indoors, and keep both ends of the pipes sealed until immediately before brazing. (Keep elbows and other joints wrapped in plastic.)
- Infiltration of dust, dirt, or water into the refrigerant system may cause the refrigerator oil to deteriorate or cause the compressor to malfunction.
- Use a small amount of ester oil, ether oil, or alkyl benzene to coat flares and flanges.
- Infiltration of a large amount of mineral oil may cause the refrigerator oil to deteriorate.
- Charge the system with refrigerant in the liquid phase.
- If gaseous refrigerant is drawn out of the cylinder first, the composition of the remaining refrigerant in the cylinder will change and become unsuitable for use.
- Only use R410A.
- The use of other types of refrigerant that contain chloride may cause the refrigerator oil to deteriorate.

- Use a vacuum pump with a check valve.
- If a vacuum pump that is not equipped with a check valve is used, the vacuum pump oil may flow into the refrigerant cycle and cause the refrigerator oil to deteriorate.
- Prepare tools for exclusive use with R 410A. Do not use the following tools if they have been used with the conventional refrigerant: gauge manifold, charging hose, gas leak detector, check valve, refrigerant charge base, vacuum gauge, and refrigerant recovery equipment.
- If the refrigerant or the refrigerator oil that may be left on these tools are mixed in with R410A, it may cause the refrigerator oil in the new system to deteriorate. Infiltration of water may cause the refrigerator oil to deteriorate. Leak detectors for conventional refrigerants will not detect an R410A leak because R410A is free of chlorine.
- Do not use a charging cylinder.
- If a charging cylinder is used, the composition of the refrigerant in the cylinder will change and become unsuitable for use.
- Exercise special care when handling tools for use with R410A.
- Infiltration of dust, dirt, or water into the refrigerant system may cause the refrigerator oil to deteriorate.

<b>[1] FEATURES</b>	
Features.....	1
<b>[2] COMPONENTS AND FUNCTIONS</b>	
Components and functions .....	2
<b>[3] SPECIFICATIONS</b>	
3-1. Specifications .....	4
3-2. Electrical component specifications.....	5
<b>[4] OUTLINES AND DIMENSIONS</b>	
PEFY-P20· 25· 32VMR-E-L/R .....	6
<b>[5] WIRING DIAGRAM</b>	
PEFY-P20· 25· 32VMR-E-L/R .....	7
<b>[6] REFRIGERANT SYSTEM DIAGRAM</b>	
Refrigerant system diagram.....	9
<b>[7] TROUBLESHOOTING</b>	
7-1. Check methods.....	10
7-2. Address switch setting.....	12
7-3. Dipswitch setting (Factory setting).....	13
7-4. Functions of the LED on the indoor unit service board.....	13
<b>[8] DISASSEMBLY PROCEDURE</b>	
8-1. Control box .....	14
8-2. Fan and fan motor .....	15
8-3. Drainpan .....	16
8-4. LEV, thermistor (Liquid/gas pipe) .....	17
8-5. Heat exchanger .....	18
8-6. Control box internal layout.....	19
8-7. Thermistor position .....	19

**[1] FEATURES**

---

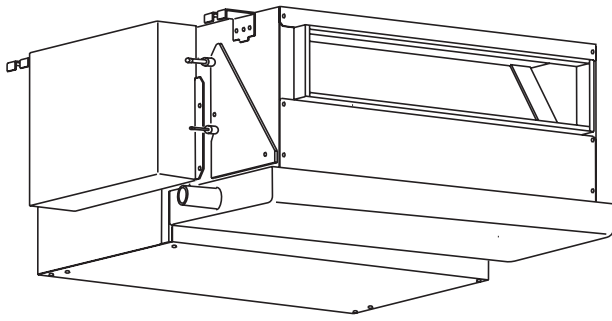

Model	Cooling capacity/Heating capacity
	kW
PEFY-P20VMR-E-L/R	2.2/2.5
PEFY-P25VMR-E-L/R	2.8/3.2
PEFY-P32VMR-E-L/R	3.6/4.0

**[2] COMPONENTS AND FUNCTIONS**

● Indoor (Main) Unit

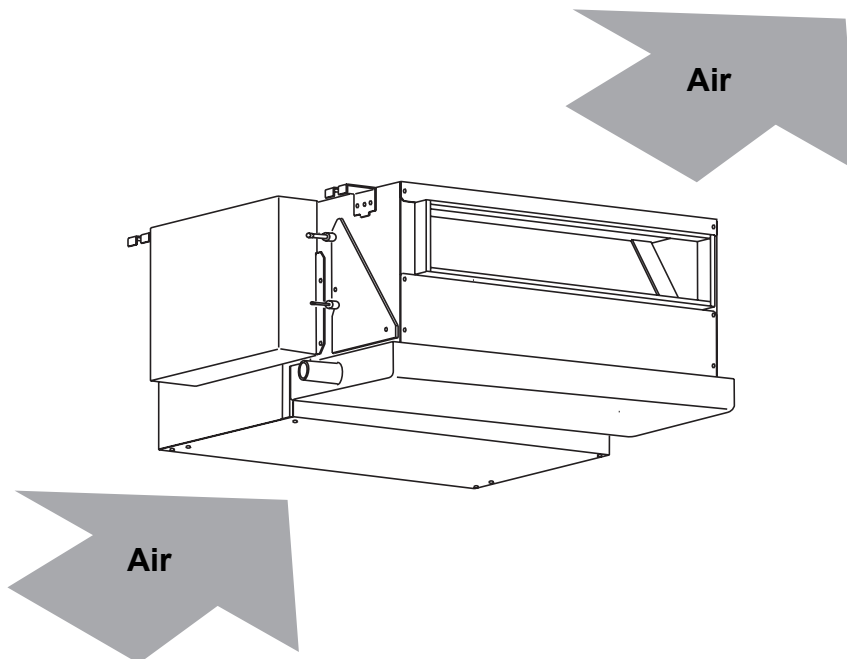

● Remote controller

**[PAR-21MAA]**

- Once the operation mode is selected, the unit will remain in the selected mode until changed.

**[Remote Controller Button]**

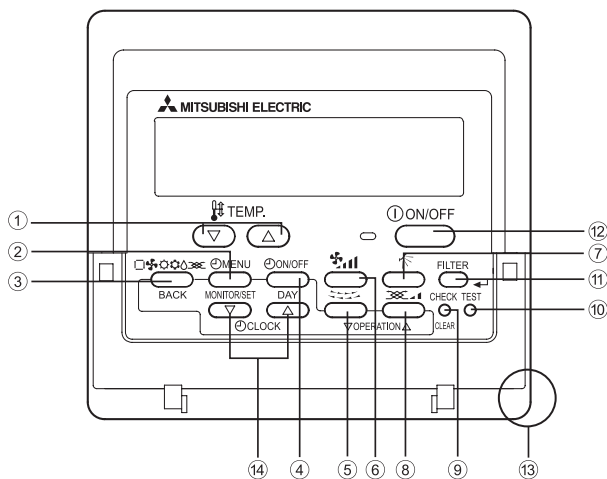

- |  |                         |
|--|-------------------------|
| ① [Set Temperature] Button                         | ③ [Mode] Button         |
| ② [Timer Menu] Button                              | ④ [Back] Button         |
| ④ [Timer On/Off] Button                            | ⑤ [Louver] Button       |
| ④ [Set Day] Button                                 | ⑥ [Operation] Button    |
| ⑥ [Fan Speed] Button                               | ⑦ [Vane Control] Button |
| ⑧ [Ventilation] Button                             |                         |
| ⑧ [Operation] Button                               |                         |
| ⑨ [Check/Clear] Button                             | ⑩ [Test Run] Button     |
| ⑪ [Filter] Button                                  | ⑫ [ON/OFF] Button       |
| ⑪ [ ] Button                                       |                         |
| ⑬ Position of built-in room temperature thermistor | ⑭ [Set Time] Button     |

- Keep the remote controller out of direct sunlight to ensure accurate measurement of room temperature.
- The sensor at the lower right-hand section of the remote controller must be free from obstructions to ensure accurate measurement of room temperature.

[Remote Controller Display]

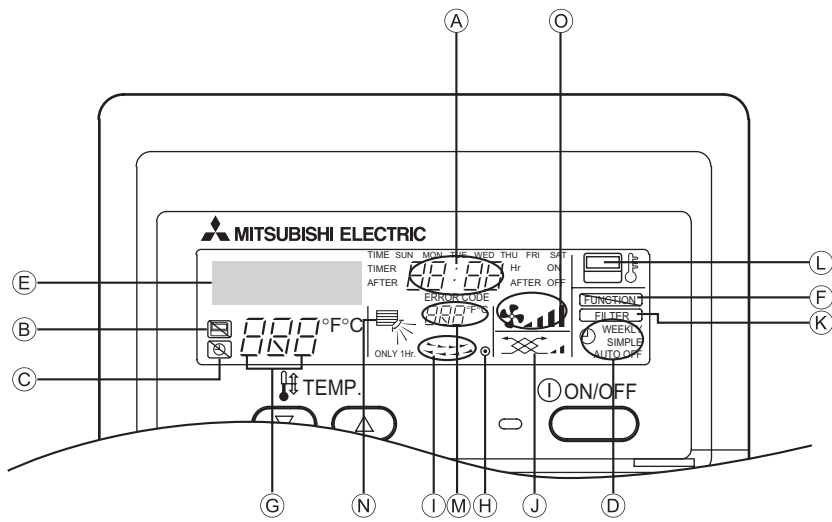

- Ⓐ Current time/Timer time
- Ⓑ Centralized control indicator
- Ⓒ Timer OFF indicator
- Ⓓ Timer mode
- Ⓔ Operation mode display: ☀️ COOL, 💧 DRY, ☐ AUTO, 🌀 FAN, 🔥 HEAT
- Ⓕ Function Lock indicator
- Ⓖ Preset temperature
- Ⓗ Power indicator
- Ⓘ Louver swing
- Ⓙ Ventilation
- Ⓚ Filter sign
- Ⓛ Thermistor position
- Ⓜ Room temperature
- Ⓝ Vane setting
- Ⓞ Fan speed

**[3] SPECIFICATIONS****3-1. Specifications**

Model			PEFY-P20VMR-E-L/R	PEFY-P25VMR-E-L/R	PEFY-P32VMR-E-L/R
Cooling capacity *1	kW		2.2	2.8	3.6
Heating capacity *1	kW		2.5	3.2	4.0
Power supply voltage/frequency			Single-phase 220/230/240 V 50Hz 220/230 V 60Hz		
Power consumption	Cooling	kW	0.06/0.06		0.07/0.08
	Heating	kW	0.06/0.06		0.07/0.08
Current consumption	Cooling	A	0.29/0.29		0.34/0.38
	Heating	A	0.29/0.29		0.34/0.38
Settable temperature range on the remote controller	Cooling	°C (°F)	19 to 30 (67 to 86)		
	Heating	°C (°F)	17 to 28 (63 to 83)		
Fan	Type × Quantity		Sirocco fan × 1		
	External static pressure		5		
			Single-phase induction motor		
	Motor output	kW	0.018	0.023	
	Driving mechanism		Direct-driven		
	Airflow rate (Low-Mid-High)	m <sup>3</sup> /min	4.8-5.8-7.9		4.8-5.8-9.3
External finish			Galvanized		
External dimensions H × W × D	Rear inlet model	mm	292 × 640 × 580		
		In.	11-1/2 × 25-1/4 × 22-7/8		
	Bottom inlet model	mm	300 × 640 × 570		
		In.	11-7/8 × 25-1/4 × 22-1/2		
Net weight		kg	18		
Wire	Min. wire size	mm (in.)	1.6 (1/8)		
	Breaker amperage	A	16		
Refrigerant pipe diameter	Liquid R410A	mm (in.)	ø6.35 (ø1/4) Brazed connection		
	Gas R410A	mm (in.)	ø12.7(ø1/2) Brazed connection		
Drain pipe diameter		mm (in.)	Drain hose O.D. 26 (1-1/32)		
Operating noise *2 (Low-Mid-High) (measured in anechoic room)	220V	dB<A>	20-25-30	20-25-33	
	230V	dB<A>	21-26-32	21-26-35	
	240V	dB<A>	22-27-30	22-27-33	
Insulation material			Polyethylene foam, Urethane foam		
Air filter			PP Honeycomb fabric (washable)		
Refrigerant control device			LEV		
Connectable outdoor unit			R410A CITY MULTI		
Protection devices			Fuse		
Heat exchanger			Cross fin (Aluminium fin and copper tube)		

Note: \*1 Maximum capacity of the unit under the following conditions

<Cooling> Indoor temperature: 27°CDB/19°CWB (81°FDB/66°FWB) Outdoor temperature: 35°CDB (95°FDB)

<Heating> Indoor temperature: 20°CDB (68°FDB) Outdoor temperature: 7°CDB/6°CWB (45°FDB/43°FWB)

Pipe length: 7.5m (24-9/16ft) Height difference: 0m (0ft)

\*2 Noise levels of the unit with a rear air inlet. (Noise levels are higher for the unit with a bottom air inlet.)



### 3-2. Electrical component specifications

Model Component	Symbol	PEFY-P20VMR-E-L/R	PEFY-P25VMR-E-L/R	PEFY-P32VMR-E-L/R
Transformer	T	(Primary) 50/60Hz 220-240V (Secondary) (23.5V 0.9A)		
Room temperature thermistor	TH21	Resistance 0°C/15kΩ, 10°C/9.6kΩ, 20°C/6.3kΩ, 25°C/5.4kΩ, 30°C/4.3kΩ, 40°C/3.0kΩ		
Liquid pipe thermistor	TH22	Resistance 0°C/15kΩ, 10°C/9.6kΩ, 20°C/6.3kΩ, 25°C/5.4kΩ, 30°C/4.3kΩ, 40°C/3.0kΩ		
Gas pipe thermistor	TH23	Resistance 0°C/15kΩ, 10°C/9.6kΩ, 20°C/6.3kΩ, 25°C/5.4kΩ, 30°C/4.3kΩ, 40°C/3.0kΩ		
Fuse (Control board)	F1	250V 6.3A		
Fan motor (with Inner-thermostat)	MF	4-pole, Output 18W		4-pole, Output 23W
Inner-thermostat (Fan motor)		OFF 135°C±5°C ON 86°C±15°C		
Fan motor capacitor	C1	1.5μF × 440V		
Linear expansion valve	LEV	12VDC Stepping motor drive port diameter ø3.2 (0~1800 pulses <on R410-compatible outdoor units>, 0~2000 pulses <on other types of outdoor units>)		
Power supply terminal block	TB2	(L, N, ⊕) 330V 30A		
Transmission terminal block	TB5 TB15	(1, 2), (M1, M2, S) 300V 10A		

[4] OUTLINES AND DIMENSIONS

PEFY-P20· 25· 32VMR-E-L/R

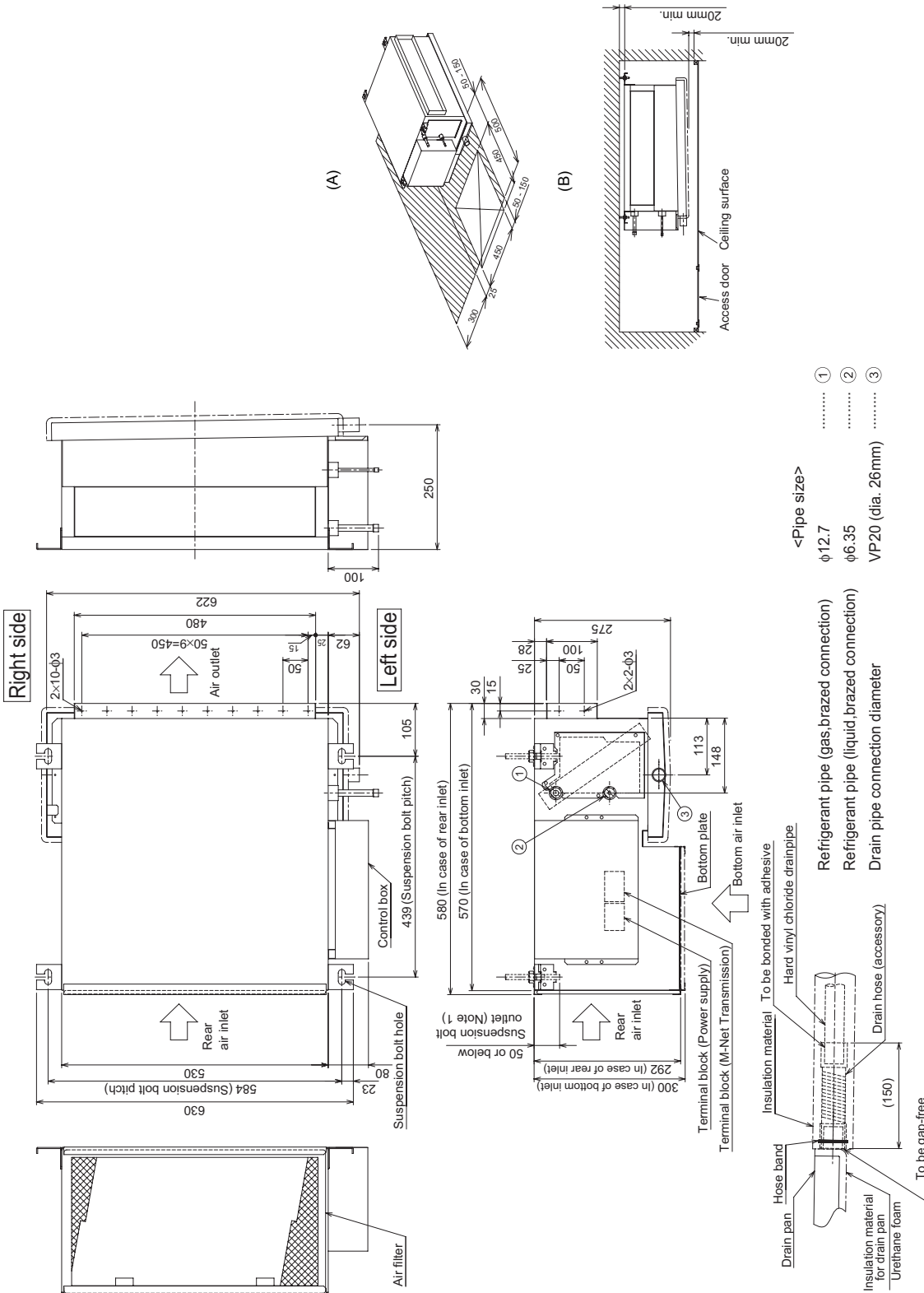

- (A) Space required for service and maintenance (Note 2)
- (B) Provide an access door as shown in the figure for maintenance.

- Note
1. Use M10 suspension bolts. (not supplied)
  2. Keep the distance between the bottom end of the suspension bolt on the heat exchanger side and the top panel of the indoor unit to no more than 50 mm to allow easy removal of the panel and access to the indoor unit heat exchanger for maintenance.
  3. Provide a 450 mm x 450 mm access door in the ceiling as shown below to allow access to the heat exchanger for cleaning and maintenance.
  4. The figures in this drawing show the left-piping specifications. Upside-down mirror images of these figures would show the right-piping specifications.
  5. Regular cleaning of the drain pan will prevent water overflow.
  6. Either the bottom or rear inlet can be used.
  7. Leave adequate space between the ceiling and unit when the bottom inlet is used.

[5] WIRING DIAGRAM

PEFY-P20· 25· 32VMR-E-L/R

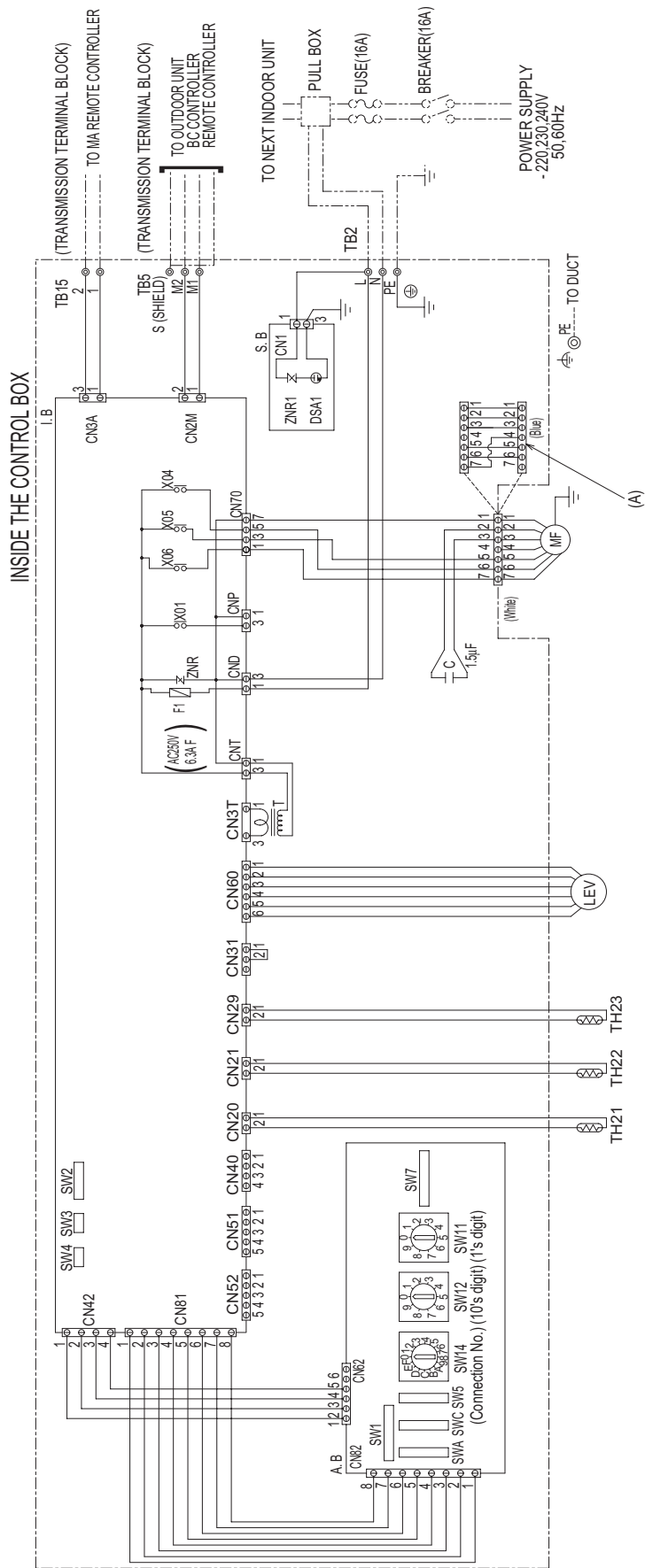

## [5] WIRING DIAGRAM

(A)  
 The fan motor connector is ready for connection to a 220V/230V power supply at factory shipment. Use blue connector adapter (supplied) to connect to a 240V power supply.  
 Coler/Power supply voltage  
 White/220V. 230V  
 Blue/240V

NOTE: 1. Wiring to TB2, TB5, and TB15 indicated by the dash-double-dotted lines is on-site work.  
 2. ⊙ terminal block, ⊖ connector.

### SYMBOL EXPLANATION

SYMBOL	NAME	SYMBOL	NAME
MF	Fan motor	TH21	Thermistor (inlet temp.)
C	Capacity (for MF) 1.5μF	TH22	Thermistor (liquid pipe temp.)
I.B	Indoor control board	TH23	Thermistor (gas pipe temp.)
A.B	Address board	SW11 (A.B)	Switch (For setting the 1's digit in the address)
TB2	Power supply terminal block	SW12 (A.B)	Switch (For setting the 10's digit in the address)
TB5	Transmission terminal block	SW14 (A.B)	Switch (connection No. setting)
TB15	Transmission terminal block	SW1 (A.B)	Switch (function setting)
F1	Fuse 250V AC 6.3A F	SW2 (A.B)	Switch (capacity code setting)
T	Transformer	SW3 (A.B)	Switch (function setting)
LEV	Electronic linear expan. valve	SW4 (A.B)	Switch (model setting)
S.B	Surge absorber board	SW5 (A.B)	Switch (voltage setting)
X04~X06	Aux. relay	SW7 (A.B)	Switch (function setting)

**[6] REFRIGERANT SYSTEM DIAGRAM**

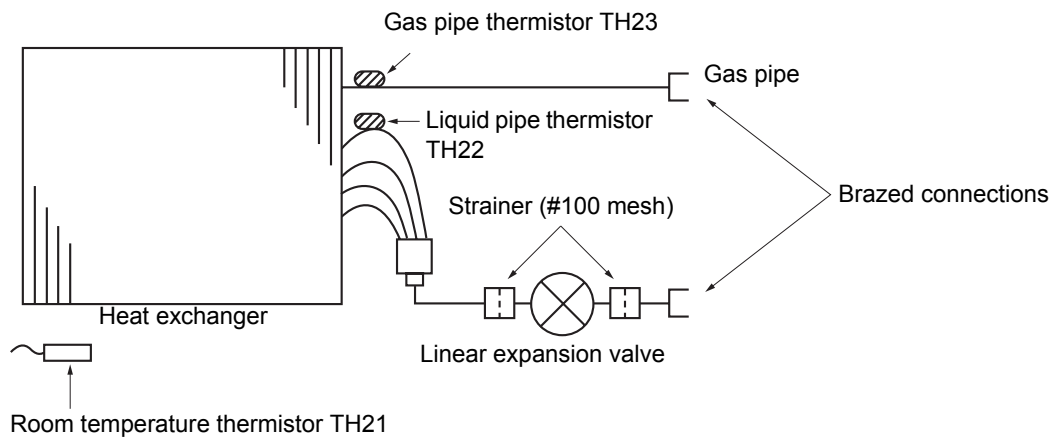

Capacity	PEFY-P20, 25, 32VMR-E-L/R
Gas pipe	ø12.7<1/2>
Liquid pipe	ø6.35<1/4>

## [7] TROUBLESHOOTING

### 7-1. Check methods

#### 1. Component and Check points

##### (1) Thermistor

- Room temperature thermistor (TH21)
- Liquid pipe thermistor (TH22)
- Gas pipe thermistor (TH23)

Disconnect the connector, and measure the resistance with a tester.  
(Ambient temperature 10°C-30°C)

Normal	Abnormal
4.3kΩ-9.6kΩ	Open or short

(Refer to the thermistor characteristic graph below.)

##### (2) Transformer

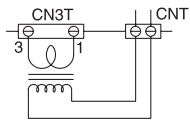

Disconnect the connector, and measure the resistance with a tester.

	Normal	Abnormal
CNT(1)-(3)	Approx. 15Ω	Open or short
CN3T(1)-(3)	Approx. 4Ω	

##### (3) Fan motor PEFY-P20· 25· 32

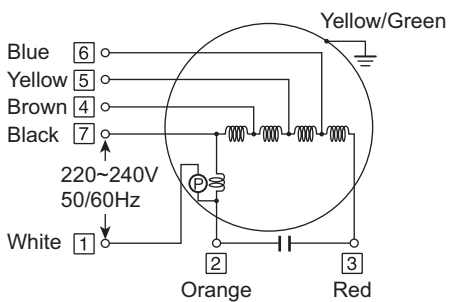

Measure the resistance between the terminals with a tester. (at 20°C)

Motor terminal or Relay connector	Normal		Abnormal
	P20· 25	P32	
White-Black	192Ω	164Ω	Open or short
White-Brown	214Ω	185Ω	
White-Yellow	236Ω	227Ω	
White-Blue	272Ω	257Ω	
White-Red	376Ω	355Ω	

(4) Linear expansion valve

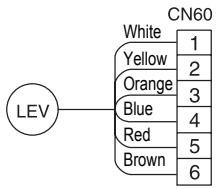

Disconnect the connector, and measure the resistance with a tester.

Normal				Abnormal
(1)-(5) White-Red	(2)-(6) Yellow-Brown	(3)-(5) Orange-Red	(4)-(6) Blue-Brown	Open or short
150Ω ±10%				

<Thermistor characteristic graph>

Room temperature thermistor (TH21)

Liquid pipe thermistor (TH22)

Gas pipe thermistor (TH23)

Thermistor  $R_0=15k\Omega \pm 3\%$

Multiplier of  $B=3480k\Omega \pm 2\%$

$$R_t = 15 \exp \left\{ 3480 \left( \frac{1}{273+t} - \frac{1}{273} \right) \right\}$$

0°C 15kΩ

10°C 9.6kΩ

20°C 6.3kΩ

25°C 5.2kΩ

30°C 4.3kΩ

40°C 3.0kΩ

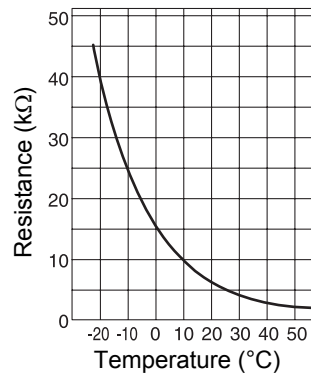

7-2. Address switch setting

Make sure that power to the unit is turned off.

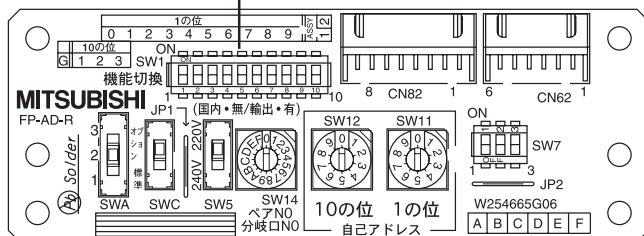
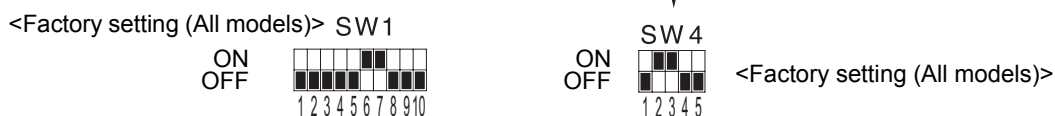
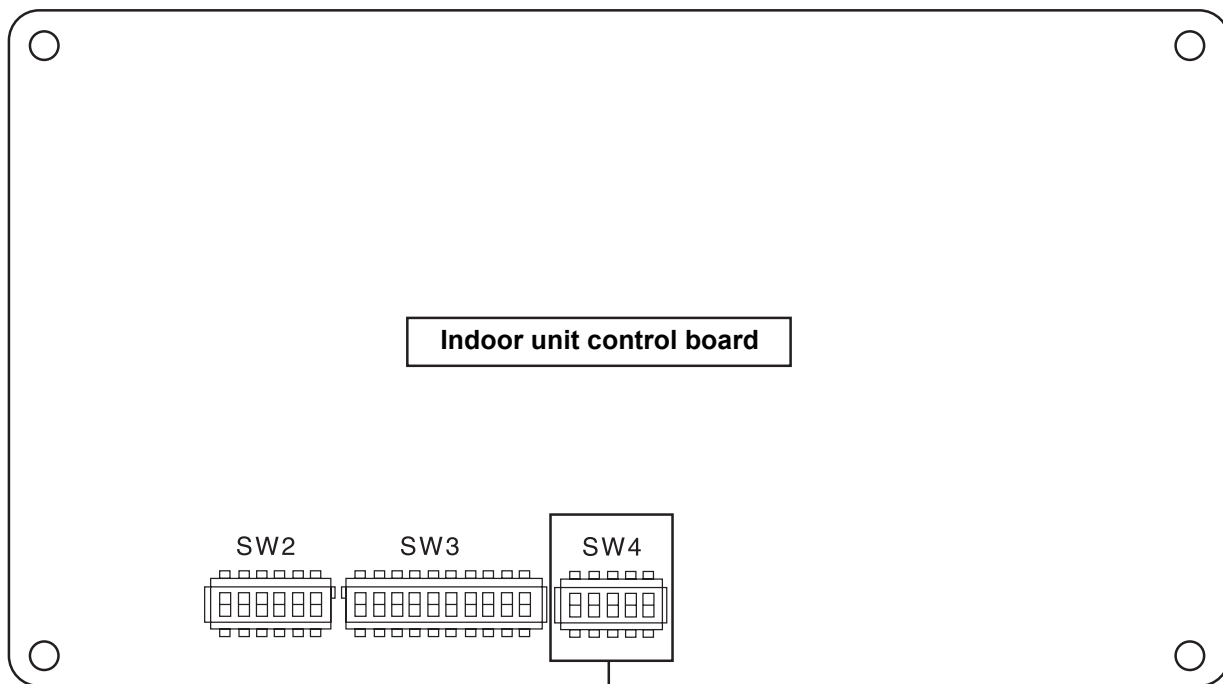

Refer to the next page for setting dipswitches SW2 and SW3.











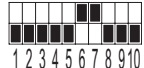

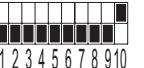











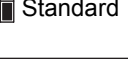
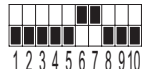



















- 1) When using an ME remote controller, set the address with the rotary switches (SW11, SW12).  
 \* Address setting is not required when the unit remote controller is used.

**On-site address setting is required for the indoor units to run.**

- 2) Address settings vary in different systems.  
 Refer to the section on address setting in the outdoor unit installation manual.
- 3) Address is set with a combination of SW12 (10's digit) and SW11 (1's digit).  
 To set the address to "3," set SW12 to "0" and SW11 to "3."  
 To set the address to "25," set SW12 to "2" and SW11 to "5."

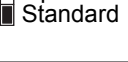

**7-3. Dipswitch setting (Factory setting)**

Group No.	Models	SW1	SW2	SW3	SW4	SW5	SW7	SWA	SWC
G01	PEFY-P20VMR-E-L	ON  1 2 3 4 5 6 7 8 9 10	ON  1 2 3 4 5 6	ON  1 2 3 4 5 6 7 8 9 10	ON  1 2 3 4 5		ON  1 2 3		
	PEFY-P20VMR-E-R	 1 2 3 4 5 6 7 8 9 10	 1 2 3 4 5 6	 1 2 3 4 5 6 7 8 9 10	 1 2 3 4 5		 1 2 3		
G02	PEFY-P25VMR-E-L	ON  1 2 3 4 5 6 7 8 9 10	ON  1 2 3 4 5 6	ON  1 2 3 4 5 6 7 8 9 10	ON  1 2 3 4 5		ON  1 2 3		
	PEFY-P25VMR-E-R	 1 2 3 4 5 6 7 8 9 10	 1 2 3 4 5 6	 1 2 3 4 5 6 7 8 9 10	 1 2 3 4 5		 1 2 3		
G03	PEFY-P32VMR-E-L	ON  1 2 3 4 5 6 7 8 9 10	ON  1 2 3 4 5 6	ON  1 2 3 4 5 6 7 8 9 10	ON  1 2 3 4 5		ON  1 2 3		
	PEFY-P32VMR-E-R	 1 2 3 4 5 6 7 8 9 10	 1 2 3 4 5 6	 1 2 3 4 5 6 7 8 9 10	 1 2 3 4 5		 1 2 3		

**7-4. Functions of the LED on the indoor unit service board**

Symbol	Printing: Silk printing	Normal LED display
LED1	Main power supply	When a voltage of 220-240 is applied to the indoor unit board → Lit
LED2	Transmission power supply	When the MA remote controller is powered → Lit

Exercise caution when removing heavy parts.

## [8] DISASSEMBLY PROCEDURE

### 8-1. Control box

#### 1. Removing the control box cover

Remove the two fixing screws on the control box, and remove the cover. (Fig. 1)

Fig. 1

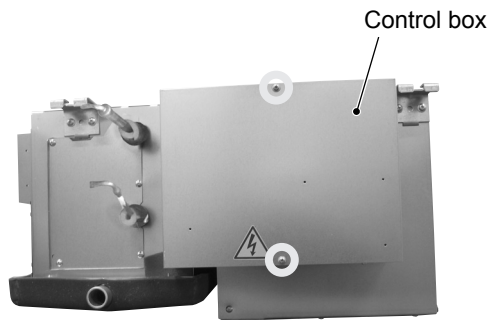

\* The following services can be performed with the cover removed. (Fig. 2)

Fig. 2

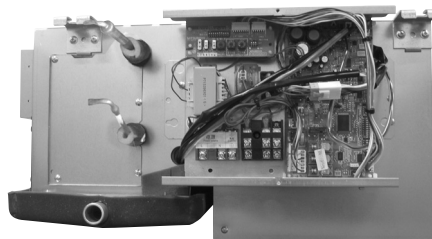

- 1 Functions of the switches on the control board.
  - Dip switch SW2..... Capacity code setting
  - Dip switch SW3..... Function setting
  - Dip switch SW4..... Model setting
- 2 Functions of the switches on the address board.
  - Rotary switches SW11, 12..... Address setting
  - Rotary switch SW14 ..... Connection No. setting
  - Dip switch SW1..... Function setting (main)
- 3 Lead wires that are connected with the control box below can be checked.
  - Power supply lead wire
  - Network remote controller transmission wire
  - Fan motor lead wire
  - LEV lead wire
  - Intake air thermistor lead wire
  - Liquid pipe thermistor lead wire
  - Gas pipe thermistor lead wire
  - Power supply transformer lead wire
  - Address board lead wire
- 4 Control board replacement
- 5 Address board replacement
- 6 Capacitor replacement
- 7 Power supply transformer replacement
- 8 Arrestor replacement
- 9 Intake air thermistor replacement
- 10 Power supply terminal block replacement
- 11 Transmission terminal block replacement

Note: Refer to "8-6. Control box internal layout" (P19) for the positions of switches on the controller board and address board.

Exercise caution when removing heavy parts.

## 8-2. Fan and fan motor

### 1. Removing the fan casing, sirocco fan, and fan motor

(1) Remove the filter. (Fig. 3)

Fig. 3

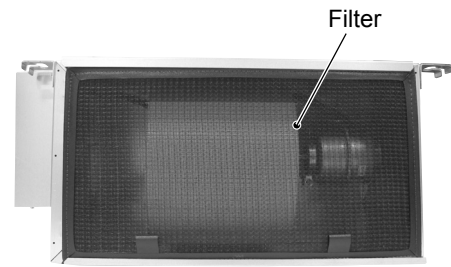

(2) Open the control box to remove the fan motor cable connector.  
(Unscrew the two fixing screws if it is difficult to remove the connector.) (Fig. 4)

Fig. 4

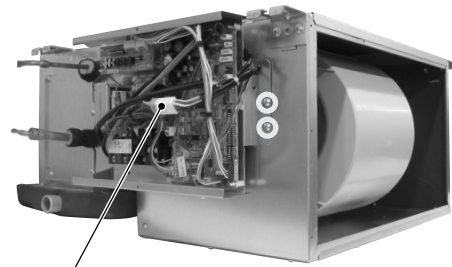

Fan motor cable connector

(3) Squeeze the four tabs on the fan casing to remove it. (Fig. 5)

Fig. 5

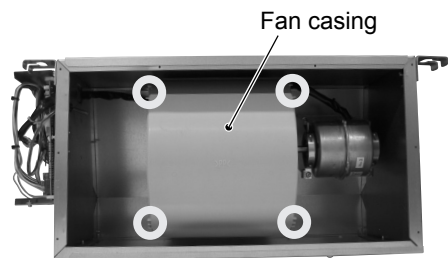

(4) Remove the set screw on the sirocco fan and the two motor set screws to remove the sirocco fan and fan motor. (Fig. 6)

Fig. 6

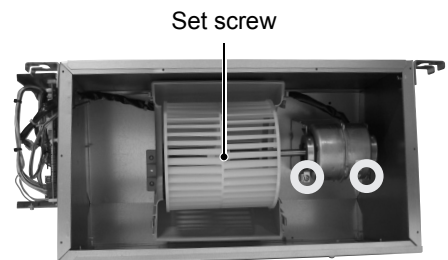

Set screw

Exercise caution when removing heavy parts.

### 8-3. Drainpan

#### 1. Removing the drainpan

(1) Remove the one fixing screw on the drainpan. (Fig. 7)

Fig. 7



(2) Slide the drainpan in the order as indicated with arrows ①, ②, and ③ to remove the drainpan. (Fig. 8)

Fig. 8

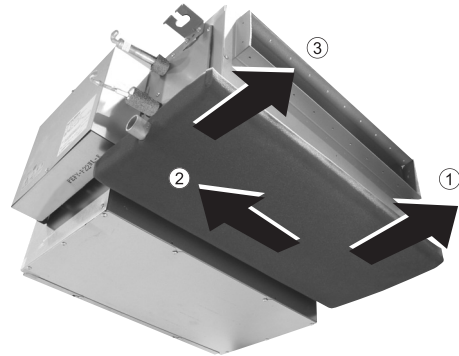

Exercise caution when removing heavy parts.

### 8-4. LEV, thermistor (Liquid/gas pipe)

#### 1. Removing the LEV

- (1) Remove the drainpan according to the procedure in section 8-3.
- (2) Remove the bottom plate by unscrewing the six fixing screws. (Fig. 9)

Fig. 9

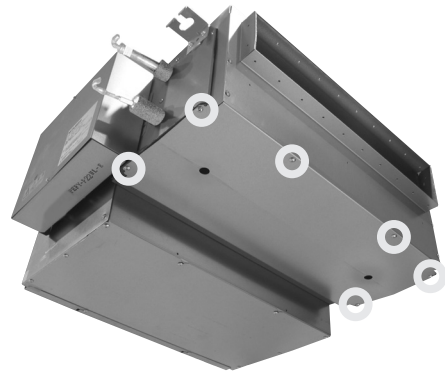

- (3) Remove the LEV driving motor using two spanners. (Fig. 10)

Fig. 10



#### 2. Removing the thermistors

- (1) Remove the thermistors from the thermistor holders on the piping. (Fig. 11)  
(Liquid piping: small diameter; Gas piping: large diameter)

Fig. 11

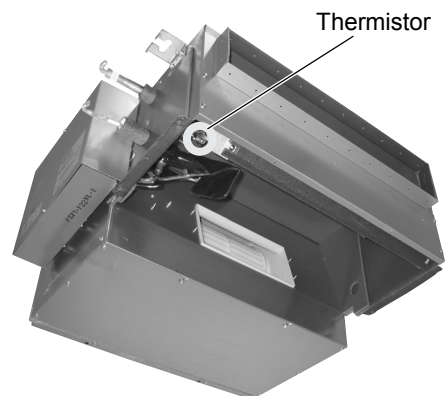

Exercise caution when removing heavy parts.

## 8-5. Heat exchanger

### 1. Removing the heat exchanger

- (1) Remove the drainpan according to the procedure in section 8-3.
- (2) Remove the bottom plate according to the procedure in section 8-4.
- (3) Remove the heat exchanger cover by unscrewing the five fixing screws. (Fig. 12)

Fig. 12

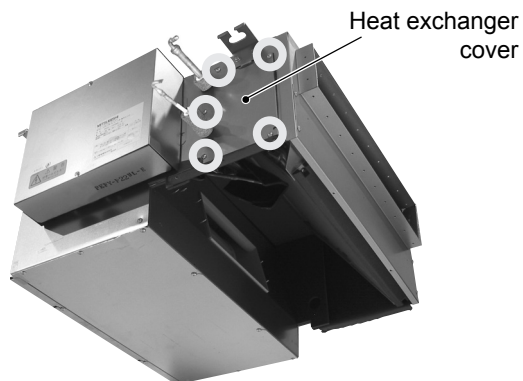

- (4) Remove the heat exchanger by unscrewing the two fixing screws. (Fig. 13)

Fig. 13

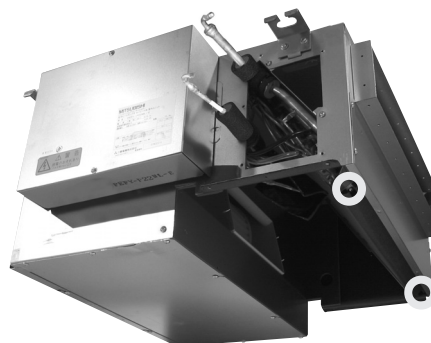

**8-6. Control box internal layout**

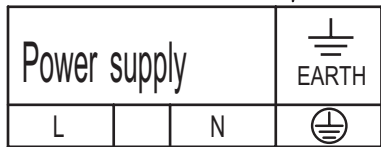
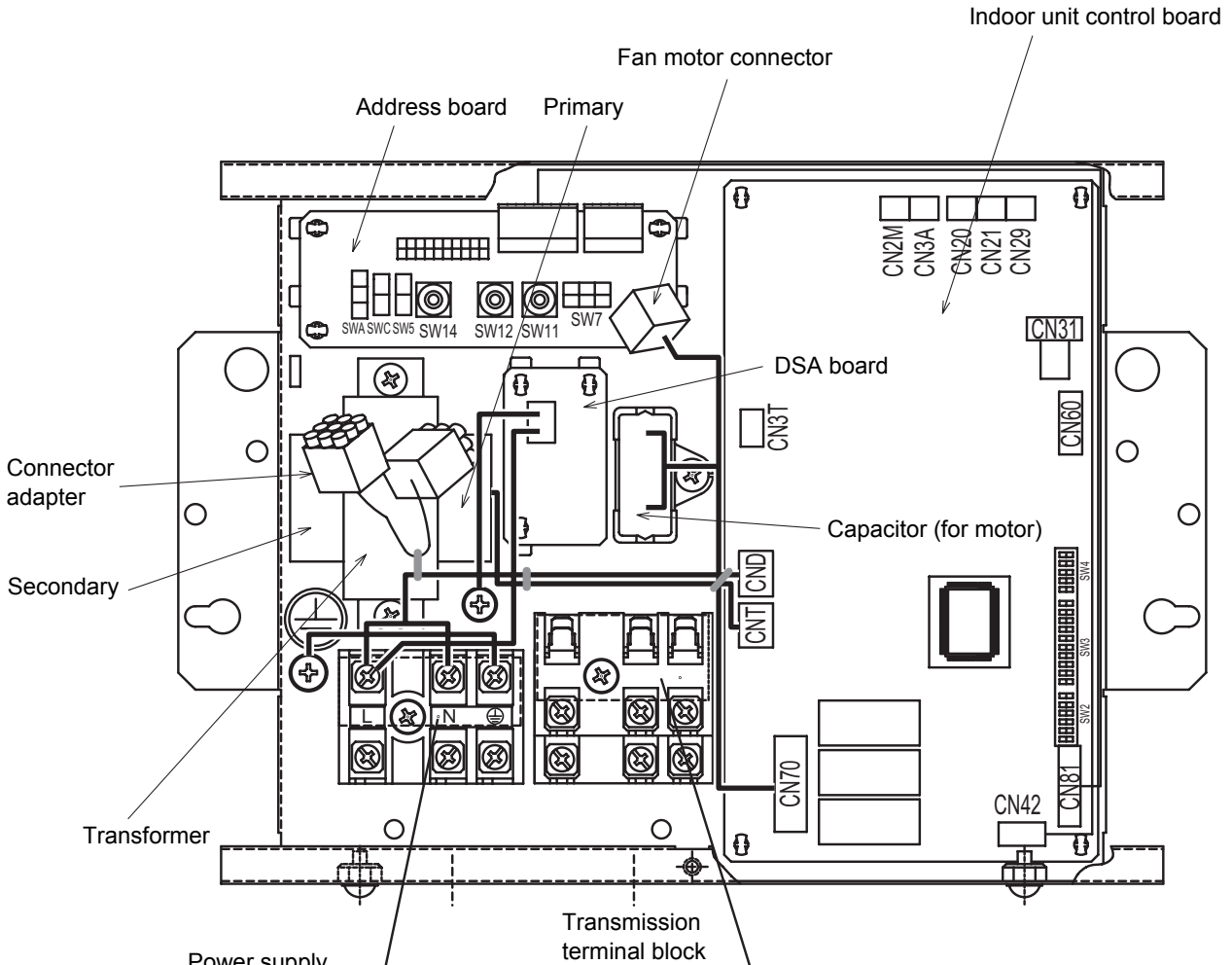

CAUTION

Never connect Power supply

MA Remo.Con.  
 1 2 TB15  
 M1 M2 S TB5  
 Transmission.  
 M-NET Remo.Con.

**8-7. Thermistor position**

